

PARTS MANUAL



MODEL LT6K 60 HZ LIGHT TOWER/GENERATOR (KOHLER KDW 1003 DIESEL ENGINE)

Revision #1 (10/22/14)

To find the latest revision of this
publication, visit our website at:
www.multiquip.com



THIS MANUAL MUST ACCOMPANY THE EQUIPMENT AT ALL TIMES.

34776

TABLE OF CONTENTS

LT6K 60 Hz Light Tower

Table Of Contents.....	2
Parts Ordering Procedures.....	3
Explanation Of Code In Remarks Column.....	4
Suggested Spare Parts	5

Component Drawings

Nameplate And Decals.....	6-3
Cabinet Assembly.....	14-15
Rear Panel Assembly.....	16-17
Front Panel Assembly.....	18-19
Ballast And Capacitor Assembly.....	20-21
Tower Assembly.....	22-23
Mast Base Assembly.....	24-25
Mast Assembly.....	26-27
Winch Assembly.....	28-29
T-Bar Assembly.....	30-31
Engine Mounting.....	32-33
Engine And Components.....	34-35
Tub/Trailer Assembly.....	36-37
Tongue Assembly.....	38-39
Jack Assy.....	40-41
Generator Assy.....	42-43
Battery Assy.....	44-45
Coil cord Assy.....	46-47
Lamp Assy.....	48-49
Control panel Assy.....	50-51
Fuel Tank, Hoses And Mounting Assy.....	52-53
Terms And Conditions Of Sale — Parts	54
Notes	55

NOTICE

Specifications and part numbers are subject to change without notice.

PARTS ORDERING PROCEDURES

Ordering parts has never been easier! Choose from three easy options:

Effective:
January 1st, 2006

www.multiquip.com



Order via Internet (Dealers Only):

Order parts on-line using Multiquip's SmartEquip website!

- View Parts Diagrams
- Order Parts
- Print Specification Information



If you have an MQ Account, to obtain a Username and Password, E-mail us at: parts@multiquip.com.

To obtain an MQ Account, contact your District Sales Manager for more information.

Goto www.multiquip.com and click on **Order Parts** to log in and save!

Use the **internet** and qualify for a **5% Discount** on *Standard orders* for all orders which include complete part numbers.*

Note: Discounts Are Subject To Change

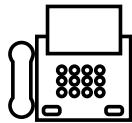

Order via Fax (Dealers Only):

All customers are welcome to order parts via Fax.

Domestic (US) Customers dial:
1-800-6-PARTS-7 (800-672-7877)

Fax your order in and qualify for a **2% Discount** on *Standard orders* for all orders which include complete part numbers.*

Note: Discounts Are Subject To Change



Order via Phone: Domestic (US) Dealers Call:
1-800-427-1244

Non-Dealer Customers:

Contact your local Multiquip Dealer for parts or call 800-427-1244 for help in locating a dealer near you.



International Customers should contact their local Multiquip Representatives for Parts Ordering information.

When ordering parts, please supply:

- | | |
|---|--|
| <input type="checkbox"/> Dealer Account Number | <input type="checkbox"/> Specify Preferred Method of Shipment: |
| <input type="checkbox"/> Dealer Name and Address | <input checked="" type="checkbox"/> UPS/Fed Ex <input checked="" type="checkbox"/> DHL |
| <input type="checkbox"/> Shipping Address (if different than billing address) | <input type="checkbox"/> Priority One <input checked="" type="checkbox"/> Truck |
| <input type="checkbox"/> Return Fax Number | <input type="checkbox"/> Ground |
| <input type="checkbox"/> Applicable Model Number | <input type="checkbox"/> Next Day |
| <input type="checkbox"/> Quantity, Part Number and Description of Each Part | <input type="checkbox"/> Second/Third Day |

NOTICE

All orders are treated as *Standard Orders* and will ship the same day if received prior to 3PM PST.

WE ACCEPT ALL MAJOR CREDIT CARDS!



EXPLANATION OF CODE IN REMARKS COLUMN

The following section explains the different symbols and remarks used in the Parts section of this manual. Use the help numbers found on the back page of the manual if there are any questions.

NOTICE

The contents and part numbers listed in the parts section are subject to change **without notice**. Multiquip does not guarantee the availability of the parts listed.

SAMPLE PARTS LIST

NO.	PART NO.	PART NAME	QTY.	REMARKS
1	12345	BOLT	1	INCLUDES ITEMS W/%
2%		WASHER, 1/4 IN.		NOT SOLD SEPARATELY
2%	12347	WASHER, 3/8 IN. ...	1	MQ-45T ONLY
3	12348	HOSE	A/R	MAKE LOCALLY
4	12349	BEARING	1	S/N 2345B AND ABOVE

NO. Column

Unique Symbols — All items with same unique symbol (@, #, +, %, or >) in the number column belong to the same assembly or kit, which is indicated by a note in the “Remarks” column.

Duplicate Item Numbers — Duplicate numbers indicate multiple part numbers, which are in effect for the same general item, such as different size saw blade guards in use or a part that has been updated on newer versions of the same machine.

NOTICE

When ordering a part that has more than one item number listed, check the remarks column for help in determining the proper part to order.

PART NO. Column

Numbers Used — Part numbers can be indicated by a number, a blank entry, or TBD.

TBD (To Be Determined) is generally used to show a part that has not been assigned a formal part number at the time of publication.

A blank entry generally indicates that the item is not sold separately or is not sold by Multiquip. Other entries will be clarified in the “Remarks” Column.

QTY. Column

Numbers Used — Item quantity can be indicated by a number, a blank entry, or A/R.

A/R (As Required) is generally used for hoses or other parts that are sold in bulk and cut to length.

A blank entry generally indicates that the item is not sold separately. Other entries will be clarified in the “Remarks” Column.

REMARKS Column

Some of the most common notes found in the “Remarks” Column are listed below. Other additional notes needed to describe the item can also be shown.

Assembly/Kit — All items on the parts list with the same unique symbol will be included when this item is purchased.

Indicated by:

“INCLUDES ITEMS W/(unique symbol)”

Serial Number Break — Used to list an effective serial number range where a particular part is used.

Indicated by:

“S/N XXXXX AND BELOW”

“S/N XXXX AND ABOVE”

“S/N XXXX TO S/N XXX”

Specific Model Number Use — Indicates that the part is used only with the specific model number or model number variant listed. It can also be used to show a part is NOT used on a specific model or model number variant.

Indicated by:

“XXXXX ONLY”

“NOT USED ON XXXX”

“Make/Obtain Locally” — Indicates that the part can be purchased at any hardware shop or made out of available items. Examples include battery cables, shims, and certain washers and nuts.

“Not Sold Separately” — Indicates that an item cannot be purchased as a separate item and is either part of an assembly/kit that can be purchased, or is not available for sale through Multiquip.

SUGGESTED SPARE PARTS

LT6K LIGHT TOWER

1 to 3 units

Qty.	P/N	Description
2	MVR1000BT37	BULB, LIGHT FIXTURE
1	190ZQREF	REF 1000 LENS
1	200ZG106	GASKET, U-CHANL REFLEC
1	12009	FILTER, IN-TANK (FUEL)
1	29694	CAP, FUEL W/LANYARD
1	59006	EXCITATION CAPACITOR
1	19598	CAPACITOR 24uF LAMP BALLAST
1	34098	CIRCUIT BREAKER, 15A
2	34097	CIRCUIT BREAKER, 20A
1	34096	CIRCUIT BREAKER, 30A
1	34093	JACK, 2000#, 10" TOP WIND
1	34101	COVER, ACCESS PANEL
1	34378	GASKET, ACCES PANEL
1	16185	FITTING, PLUG

KOHLER KDW1003 DIESEL ENGINE

1 to 3 units

Qty.	P/N	Description
3	ED0021752880S	FUEL FILTER
3	ED0021752830S	OIL FILTER
3	ED0021751640S	CARTRIDGE, AIR FILTER
1	ED0024403200S	FAN BELT
1	ED0067450560S	OIL PRESSURE SWITCH
2	ED34001S	KEY, IGNITION, DBL SIDED

NOTICE

Part numbers on this Suggested Spare Parts list may supersede/replace the part numbers shown in the following parts lists.

NAMEPLATE AND DECALS

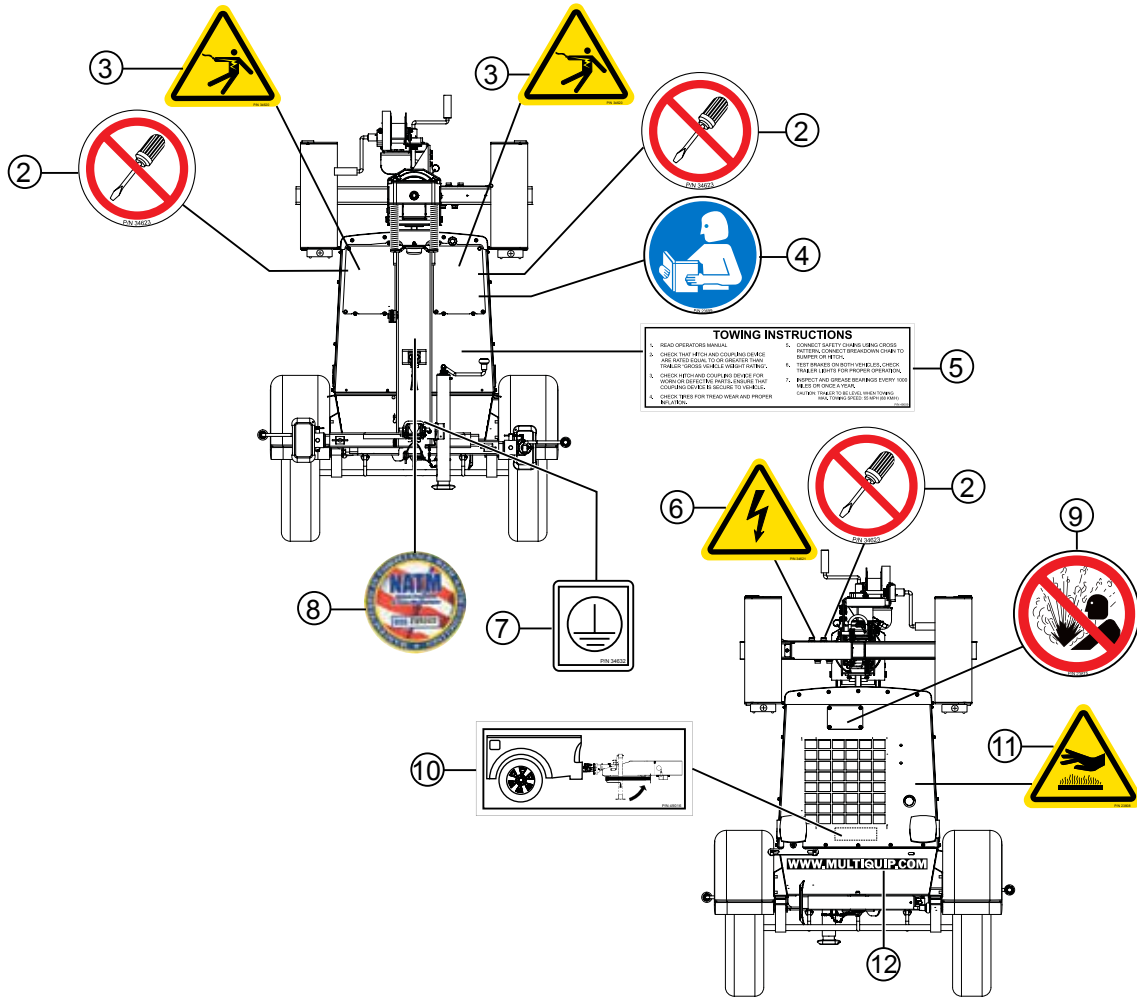

NAMEPLATE AND DECALS

<u>NO.</u>	<u>PART NO.</u>	<u>PART NAME</u>	<u>QTY.</u>	<u>REMARKS</u>
2	34623	DECAL ISO: DO NOT DISASSEMBLE HAZARD, 2.00" DIA.	3	
3	34620	DECAL ISO: ELECTROCUTION HAZARD, 2.4" X 2.0"	2	
4	23699	DECAL ISO: READ MANUAL, 2.00" DIA.	1	
5	49009	DECAL: TOWING INSTRUCTIONS, 7.75" X 2.5	1	
6	34621	DECAL ISO: HIGH VOLTAGE HAZARD, 2.4" X 2.0"	1	
7	34632	DECAL ISO: GROUND 1.00" X 1.00"	1	
8	EE56342	DECAL: NATM, 2.75" DIA.	1	
9	23875	DECAL ISO: HOT COOLANT HAZARD, 2.00" DIA.	1	
10	49016	DECAL: HORIZONTAL JACK STANDS 4.10" X 1.80"	3	
11	23808	DECAL ISO: HOT SURFACE HAZARD 2.4" X 2.00"	2	
12	34808	DECAL: MQ WEBSITE 18.00" X 1.20"	1	

NAMEPLATE AND DECALS

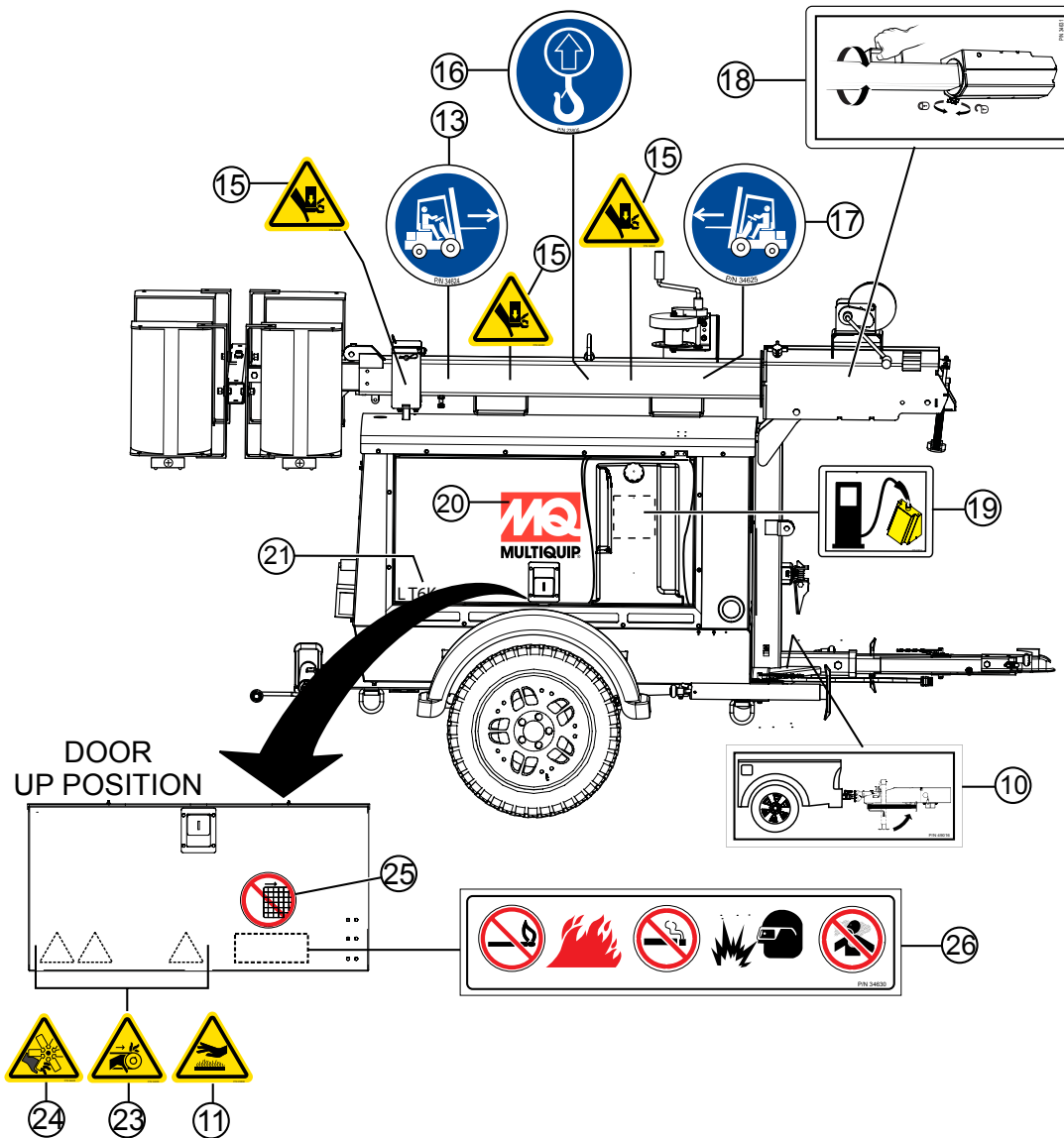

NAMEPLATE AND DECALS

<u>NO.</u>	<u>PART NO.</u>	<u>PART NAME</u>	<u>QTY.</u>	<u>REMARKS</u>
10	49016	DECAL: HORIZONTAL JACK STANDS 4.10" X 1.80"	3	
11	23808	DECAL ISO: HOT SURFACE HAZARD 2.4" X 2.00"	2	
13	34624	DECAL ISO: FORK LIFT LEFT 2.00" DIA.	2	
15	34622	DECAL ISO: CRUSH HAZARD 2.4" X 2.0"	6	
16	34626	DECAL ISO: LIFTING POINT 2.00" DIA	2	
17	34625	DECAL ISO: FORK LIFT RIGHT 2.00" DIA	2	
18	34631	DECAL: MAST ROTATION, 2.00" X 2.45"	1	
19	23813	DECAL: FUEL, DIESEL 2.00" X 2.45"	1	
20	34806	DECAL: MQ LOGO 12.00" X 10.00"	2	
21	34807	DECAL: LT6K LOGO 8.00" X 3.00"	2	
23	34629	DECAL ISO: ENTANGLEMENT HAZARD, 2.4" X 2.00"	2	
24	34628	DECAL ISO: BLADE ROTATION HAZARD, 2.4" X 2.00"	2	
25	23874	DECAL ISO: DO NOT REMOVE GUARDS HAZARD 2.00" DIA.	2	
26	34630	DECAL: FIRE, EXPLOSION, SMOKING HAZ. 6.50" X 1.40"	1	

NAMEPLATE AND DECALS

<u>NO.</u>	<u>PART NO.</u>	<u>PART NAME</u>	<u>QTY.</u>	<u>REMARKS</u>
1		DECAL: SERIAL PLATE	1CONTACT MQ PARTS DEPT
10	49016	DECAL: HORIZONTAL JACK STANDS 4.10" X 1.80"	3	
13	34624	DECAL ISO: FORK LIFT LEFT 2.00" DIA.	2	
14	49911	DECAL: WARNING UV RADIATION, 6.50" X 3.40"	1	
15	34622	DECAL ISO: CRUSH HAZARD 2.4" X 2.0"	6	
16	34626	DECAL ISO: LIFTING POINT 2.00" DIA	2	
17	34625	DECAL ISO: FORK LIFT RIGHT 2.00" DIA	2	
20	34806	DECAL: MQ LOGO 12.00" X 10.00"	2	
21	34807	DECAL: LT6K LOGO 8.00" X 3.00"	2	
22	34633	DECAL: OPERATING INSTRUCTIONS 13.25" X 13.25"	1	
23	34629	DECAL ISO: ENTANGLEMENT HAZARD, 2.4" X 2.00"	2	
24	34628	DECAL ISO: BLADE ROTATION HAZARD, 2.4" X 2.00"	2	
25	23874	DECAL ISO: DO NOT REMOVE GUARDS HAZARD 2.00" DIA.	2	
31	34634	DECAL: MAST OPERATING INSTR., 16.23" X 5.2"	1	

NAMEPLATE AND DECALS

⚠ WARNING	⚠ WARNING	⚠ WARNING	⚠ WARNING
<p>To prevent uncoupling from the tow vehicle perform the following:</p> <ol style="list-style-type: none"> CHECK BALL and COUPLER for worn or defective parts. CHECK that BALL and COUPLER is the same size or greater than the COUPLER and the BALL. Open COUPLER CLAMP and place onto BALL. Close COUPLER CLAMP. Lock COUPLER upwards to test that it will not separate from BALL. LOCK coupler clamp with pin or lock. 	<p>ALWAYS use safety chains. Safety chains keep unit attached to tow vehicle in the event of coupler malfunction.</p> <p>Perform the following when attaching safety chains:</p> <p>TOW VEHICLE FRAME</p> <ol style="list-style-type: none"> CROSS 6 chains underneath coupler. ALLOW for slack for trailer to turn. ATTACH safety chain hooks securely to tow vehicle frame. 	<p>Lights can prevent trailer from being hit by other vehicles. Perform the following when connecting the trailer lights:</p> <p>DISCONNECTED</p> <p>CONNECTED</p> <ol style="list-style-type: none"> CONNECT trailer and tow vehicle light plugs. CHECK all lights: ball, turn, signal and brake. Make sure all lights are working properly. DO NOT TO W if lights are not working correctly. 	<p>Tire, wheel or lug nut failure can cause loss of control. Perform the following before towing:</p> <ol style="list-style-type: none"> CHECK tire pressure and tread. CHECK tire and wheel for damage. CHECK lug nuts for tightness. For new and resurfaced wheels re-tighten lug nuts at first 10, 25 and 50 miles of driving. CHECK and test brakes on both vehicles. INSPECT T and grease trailer bearings every 3000 miles or once a year. Trailer to be level when towing. Maximum towing speed not to exceed 55 MPH (88 KM/H). <p>TIRE AND WHEEL OK? LUG NUTS TIGHT?</p> <p>PN 34827</p>

27

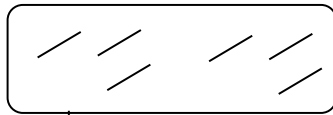
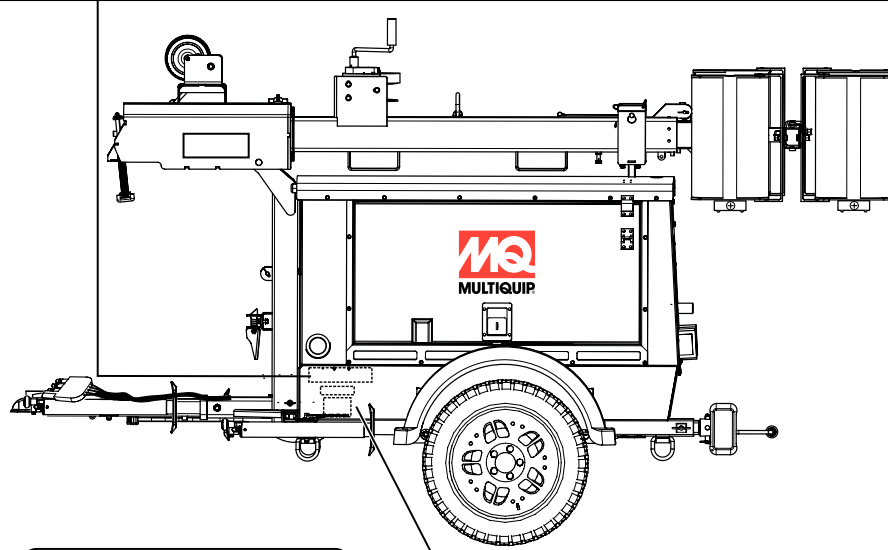

28

MANUFACTURED BY: FAYATON PARK, MULTIQUIP INC.		D DATE:
CUSTOMER: PMSV		COLD LEVEL PRESS: PRESS
COUPLER: 450001	TIRE: (PMSV)	DE COUPLER: 100000
PAIR CHAINS: 450001		REP: (PMSV) (1.1.1.1)

THE USER IS RESPONSIBLE FOR ALL DAMAGE CAUSED BY IMPROPER USE OF THE EQUIPMENT AND IS A PARTY TO THE CONTRACT FOR THE SALE OF THE EQUIPMENT. THE USER IS RESPONSIBLE FOR ALL DAMAGE CAUSED BY IMPROPER USE OF THE EQUIPMENT AND IS A PARTY TO THE CONTRACT FOR THE SALE OF THE EQUIPMENT.

THE USER IS RESPONSIBLE FOR ALL DAMAGE CAUSED BY IMPROPER USE OF THE EQUIPMENT AND IS A PARTY TO THE CONTRACT FOR THE SALE OF THE EQUIPMENT.

LANGUAGE: TYPICAL TRAILER

29

THE USER IS RESPONSIBLE FOR ALL DAMAGE CAUSED BY IMPROPER USE OF THE EQUIPMENT AND IS A PARTY TO THE CONTRACT FOR THE SALE OF THE EQUIPMENT.	
The weight of any load on or over the trailer must not exceed the rated capacity of the trailer.	
MAX. WEIGHT	MAX. LOAD
MAX. WEIGHT	MAX. LOAD
MAX. WEIGHT	MAX. LOAD
MAX. WEIGHT	MAX. LOAD

30

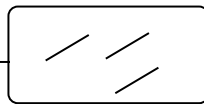

NAMEPLATE AND DECALS

<u>NO.</u>	<u>PART NO.</u>	<u>PART NAME</u>	<u>QTY.</u>	<u>REMARKS</u>
27	34627	DECAL: WARNING, TOWING 13.1" X 2.3"	1	
28	EE56313	OVERLAY	1	
29		DECAL: VIN AND TIRE TAG.....	1.....	CONTACT MQ PARTS
		DEPT.
30	EE56314	OVERLAY	1	

CABINET ASSY.

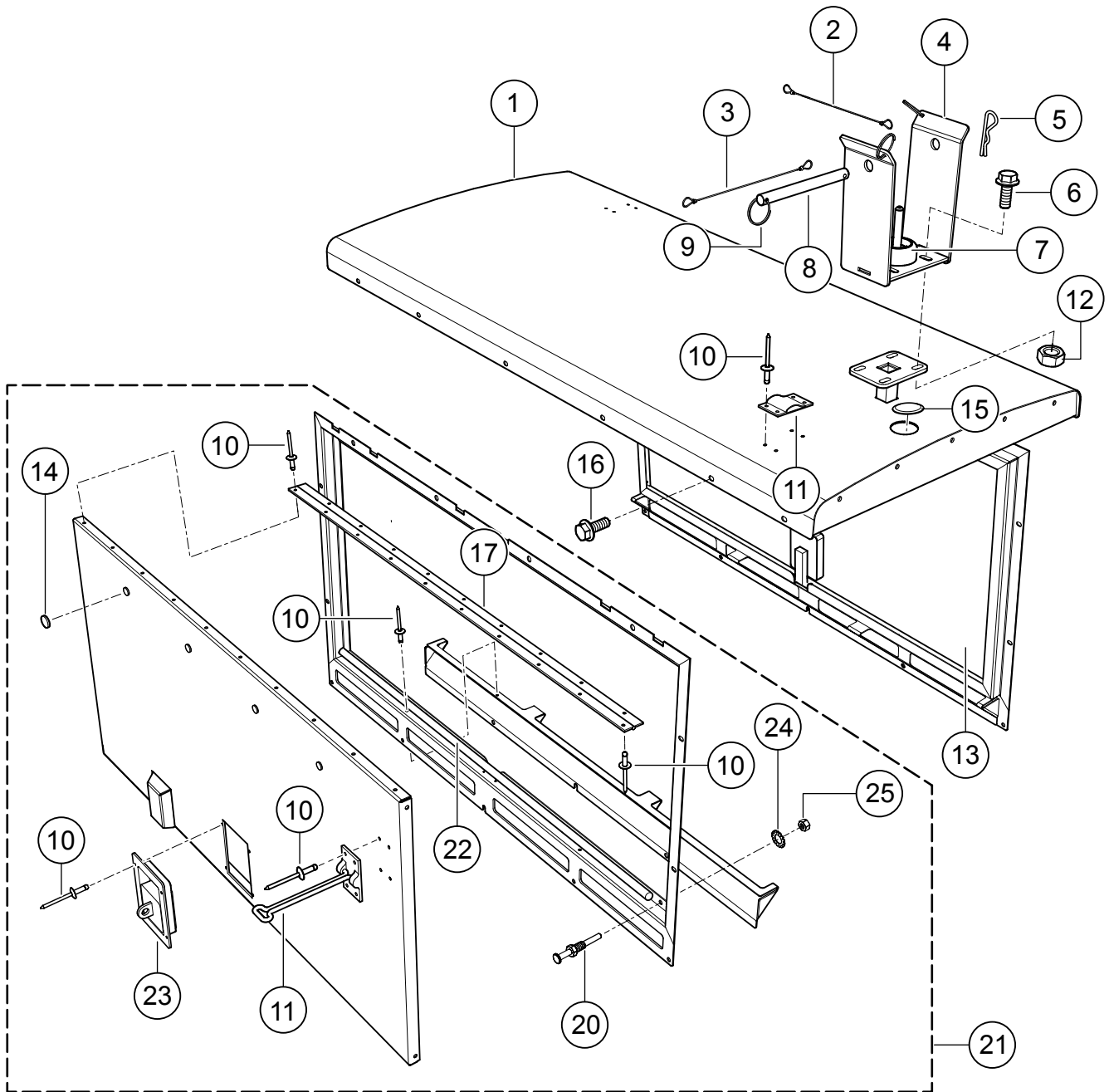

CABINET ASSY.

<u>NO.</u>	<u>PART NO.</u>	<u>PART NAME</u>	<u>QTY.</u>	<u>REMARKS</u>
1	34642	LID, CABINET	1	
2	19483	LANYARD 6"	1	
3	19484	LANYARD 10"	1	
4	34149	MAST SUPPORT	1	
5	34103	PIN, HAIRPIN COTTER, ZN. 2-9/16" L	1	
6	9091	SCREW, HHFS 5/16-18 X 1" GRD5	4	
7	17336	BUMPER, 2.5" DIA X 1"	1	
8	34105	PIN, ZINC PLTD., 1018 STEEL	1	
9	34102	RING, SPLIT, ZN PLTD., 1.06" ID	3	
10\$#	19847	RIVET, POP, ALUM. 3/16" X 1/8-1/4" GRIP	AR	
11\$#	34721	HOOK AND LATCH ASSY., 6"	2	
12	49071	NUT, FLANGED 5/16-18 SERRATED PLTD	4	
13	34651	DOOR ASSY, RIGHT	1	INCLUDES ITEMS W/#
14\$#	29711	BUMPER, 1/2" DIA. BLACK	8	
15	20121	PLUG, SNAP IN	1	
16	30119	SCREW, HHFS 1/4-20 X 7/8" IND HEX, DOG PT	AR	
17\$#	34658	HINGE, DOOR	2	
20\$	39171	SWITCH, MOMENTARY DOOR	1	
21	34761	DOOR, ASSY., LEFT	1	INCLUDES ITEMS W/\$
22\$#	29093	GASKET, 4' PER SIDE	8	1PC=1FT
23\$#	49137	LATCH, DOOR	2	
24\$	13339	WASHER, EXT. SHKP, 5/16"	1	
25\$	0161 D	NUT, HEX FINISH 5/16-18	1	

REAR PANEL ASSY.

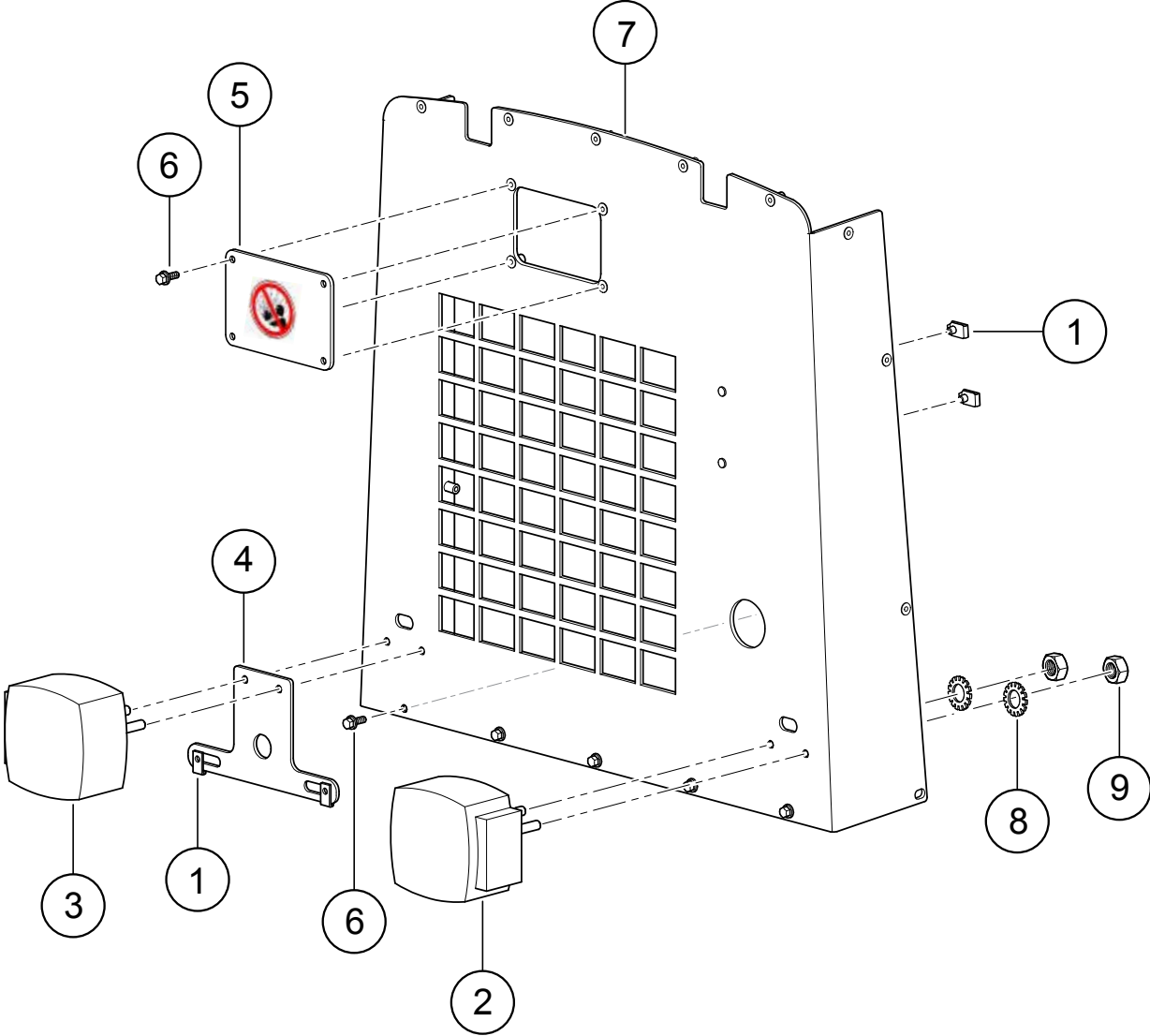

REAR PANEL ASSY.

<u>NO.</u>	<u>PART NO.</u>	<u>PART NAME</u>	<u>QTY.</u>	<u>REMARKS</u>
1	11534	NUT, "U" TYPE, 1/4-20	4	
2	29242	LIGHT, TAIL RIGHT (CURBSIDE)	1	
3	29243	LIGHT, LEFT TAIL LIGHT (ROAD SIDE)	1	
4	34682	BRACKET, LICENSE PLATE	1	
5	34877	COVER, RAD FILL ACCESS, W/GASKET & DECAL	1	
6	30119	SCREW, HHFS 1/4-20 X 7/8", IND HEX DOG PT	9	
7	34732	REAR PANEL ASM, W/ INSERTS	1	
8	10031	WASHER, EXT. SHKP, 1/4"	4	
9	49070	NUT, FLANGED 1/4-20 SERRATED PLTD	4	

FRONT PANEL ASSY.

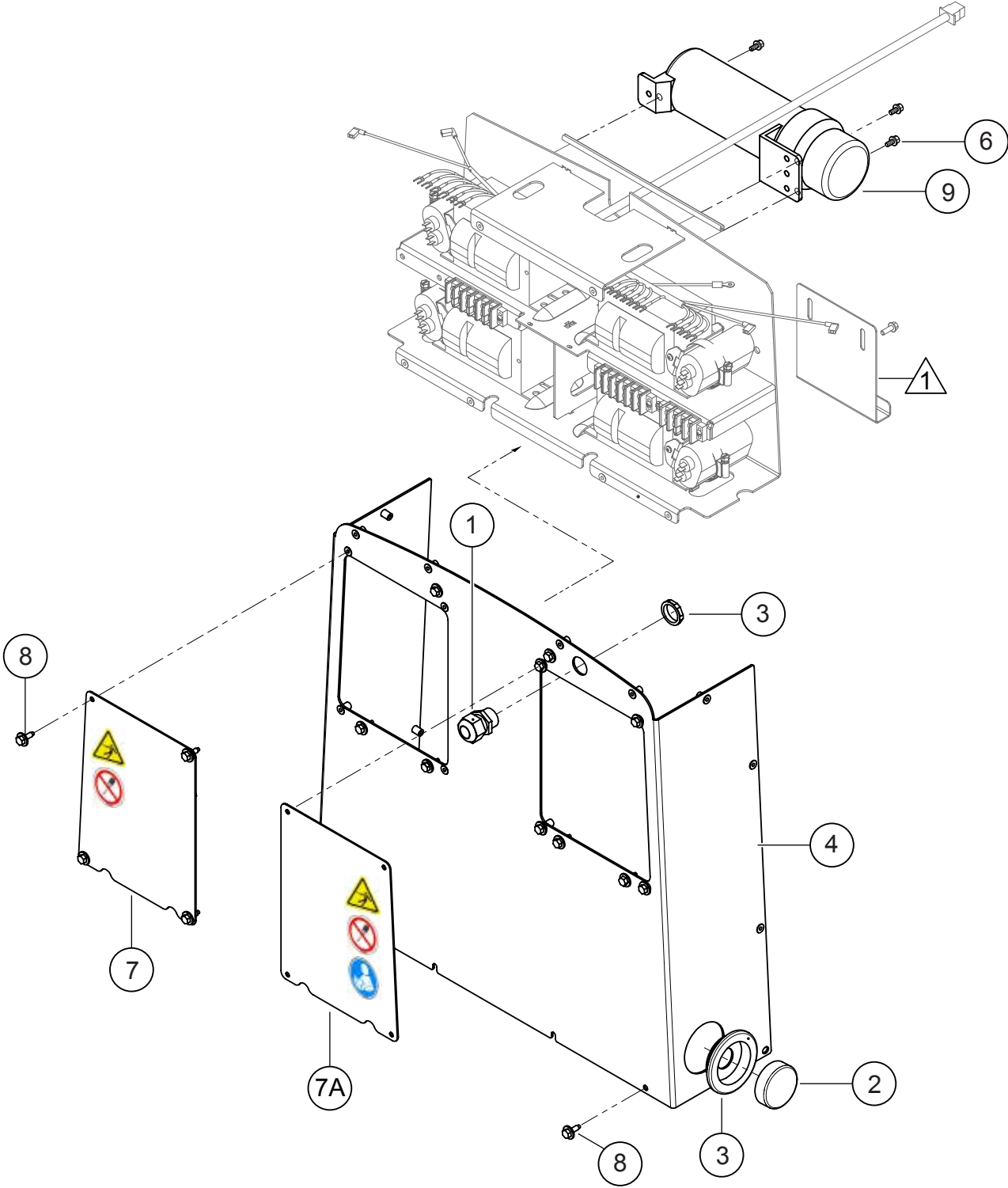

NOTE:

1 SEE FUEL TANK, HOSES, AND MOUNTING ASSY. FIGURE

FRONT PANEL ASSY.

<u>NO.</u>	<u>PART NO.</u>	<u>PART NAME</u>	<u>QTY.</u>	<u>REMARKS</u>
1	29655	CORDGRIP, LIQUID TIGHT, 3/4 NPT	1	
2	29898	LIGHT, 2-1/2" SIDE MARKER, AMBER	2	
3	29656	LOCKNUT, FLANGED NYLON, 3/4 NPT	1	
3	29900	GROMMET W/WIRE KIT, 2-1/2", 14218K	2	
4	34763	FRONT PANEL ASSY. W/INSERTS	1	
6	49048	SCREW, HHFS 1/4-20 X 3/4" GRD 5	3	
7	34879	PANEL, BALLAST ACCESS W/GASKET & DECAL	1	
7A	34878	PANEL, BALLAST ACCESS W/GASKET & DECAL	1	
8	30119	SCREW, 1/4-20 X 7/8", IND HEX DOG PT	AR	
9	23297	MANUAL HOLDER, PICTOGRAPH	1	

BALLAST AND CAPACITOR ASSY.

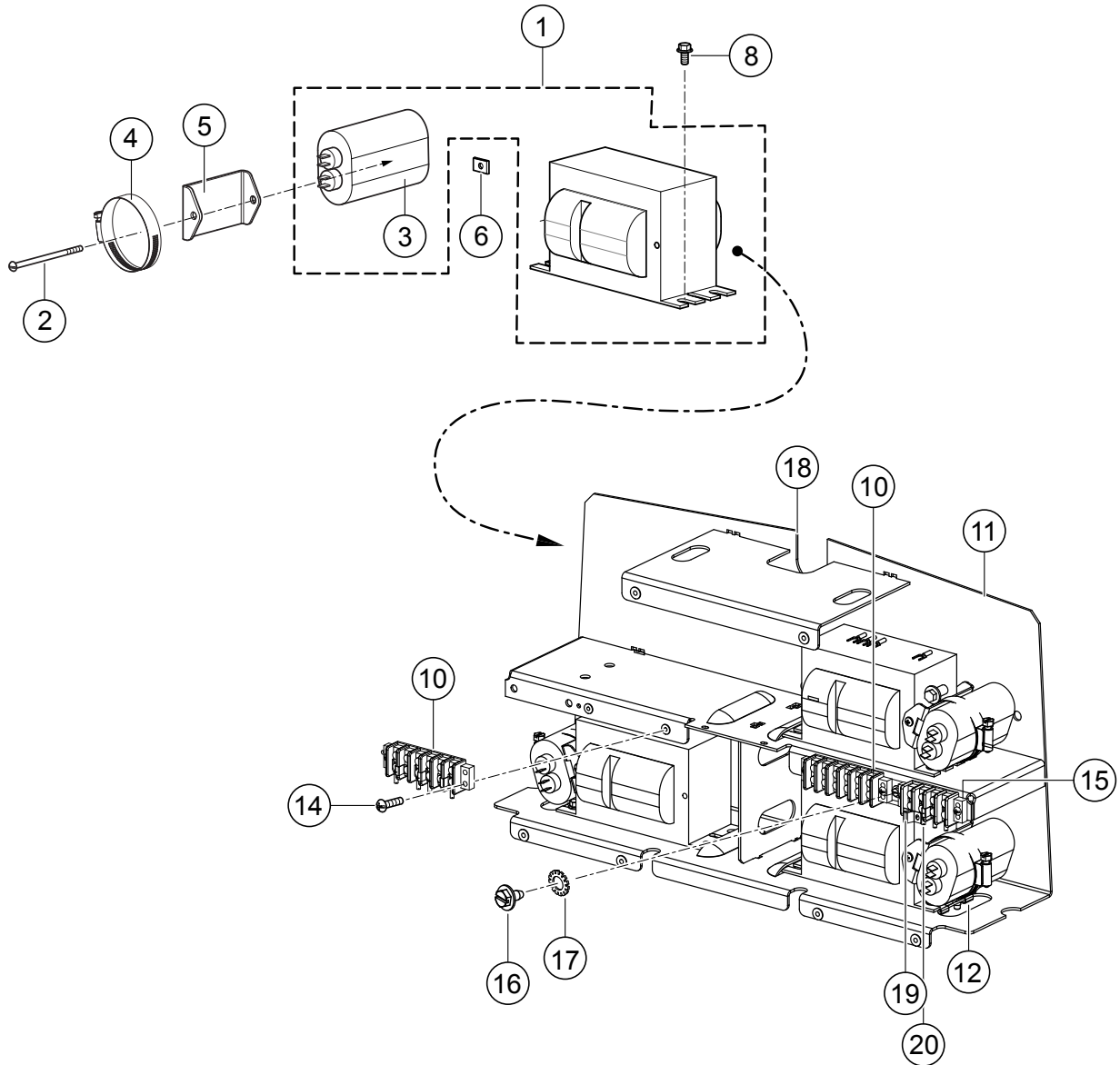

BALLAST AND CAPACITOR ASSY.

<u>NO.</u>	<u>PART NO.</u>	<u>PART NAME</u>	<u>QTY.</u>	<u>REMARKS</u>
1	34140	BALLAST/TRANSFORMER ASSY., 60Hz.....	4.....	INCLUDES ITEM W/\$
2	34820	SCREW, PHP 10-24 X 3-1/2"	4	
3\$	19598	CAPACITOR, 24uF	4	
4	12277	CLAMP, HOSE WORM #36	4	
5	34765	BRACKET, CAPACITOR, 60HZ	4	
6	34819	NUT, "U" TYPE, #10-24	4	
8	49048	SCREW, HHFS 1/4-20 X 3/4", GRD5	8	
10	34804	TERMINAL STRIP, 6 GANG DBL ROW	2	
11	34734	BALLAST MOUNT WELDMENT	1	
12	11534	NUT, "U" TYPE, 1/4-20	4	
14	8133	SCREW, PHP 10-32 X 3/4"	6	
15	34803	TERMINAL BLOCK, 2 ROW, 4 GANG	1	
16	34305	SCREW, HHF SLOT, #10-32 X 3/8" GREEN ZN	1	
17	10237	WASHER, EXT. SHKP, #10	1	
18	28861-301	RUBBER TRIM, .33'L.....	1.....	1PC=1FT
19	34833	JUMPER, TB345 TERM STRIP, #10 SCREW	4	
20	19957	TERMINAL, FLANGED SPADE, 16-14 GA X #10, INSUL	AR	

TOWER ASSY.

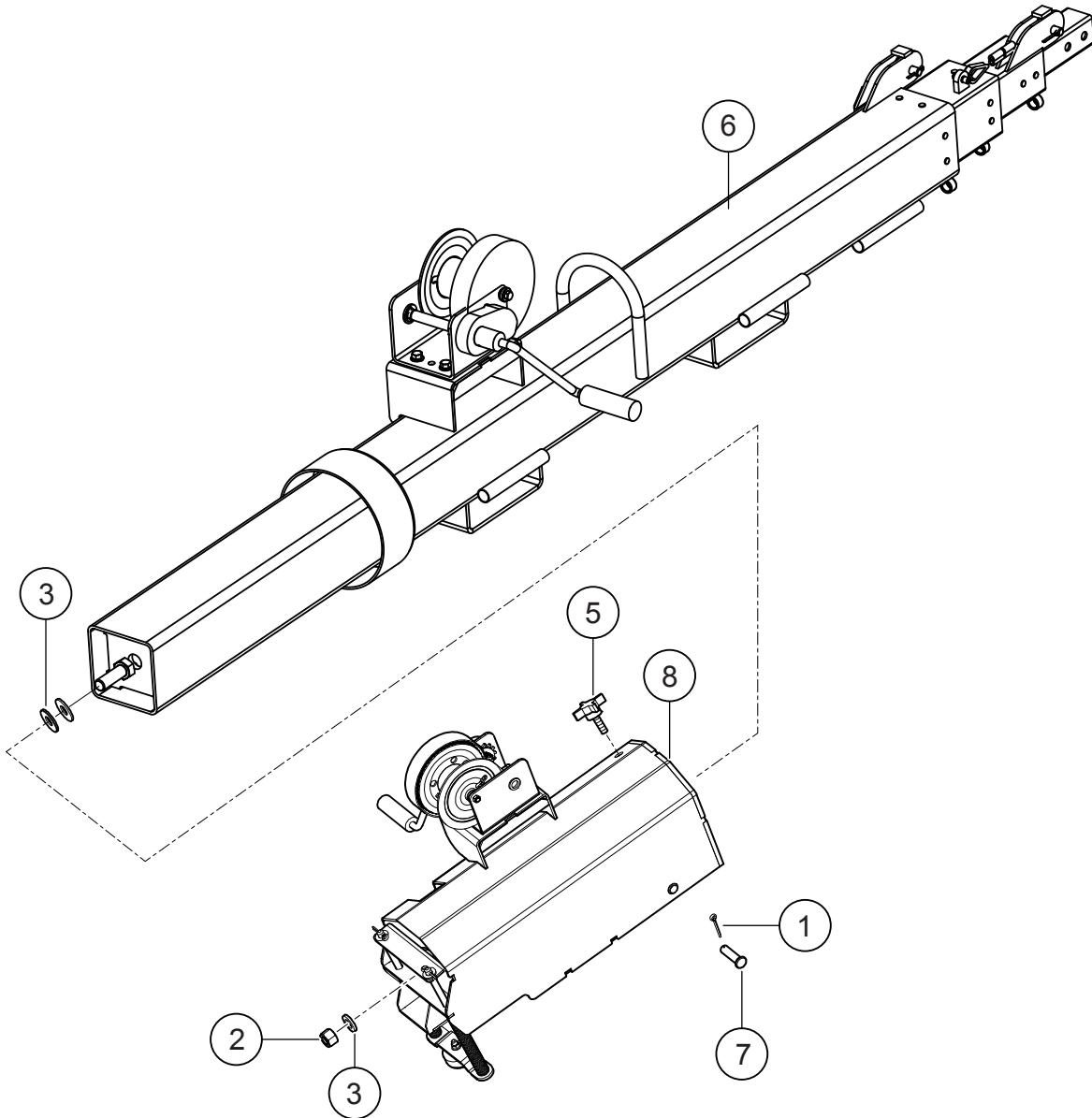

TOWER ASSY.

<u>NO.</u>	<u>PART NO.</u>	<u>PART NAME</u>	<u>QTY.</u>	<u>REMARKS</u>
1	0183	PIN, COTTER 1/8"D X 1-1/4"	2	
2	5070 B	NUT, NYLOC 3/4-10	1	
3	5079	WASHER, FLAT 3/4" USS	3	
5	19977	KNOB, CLAMP 1/2-13 THREAD	1	
6	34242	MAST ASSEMBLY	1	
7	34376	PIN,CLEVIS 5/8" X 1-3/4" EFF (2" OAL) ZP	2	
8	34751	MAST BASE ASSY.	1	

MAST BASE ASSY.

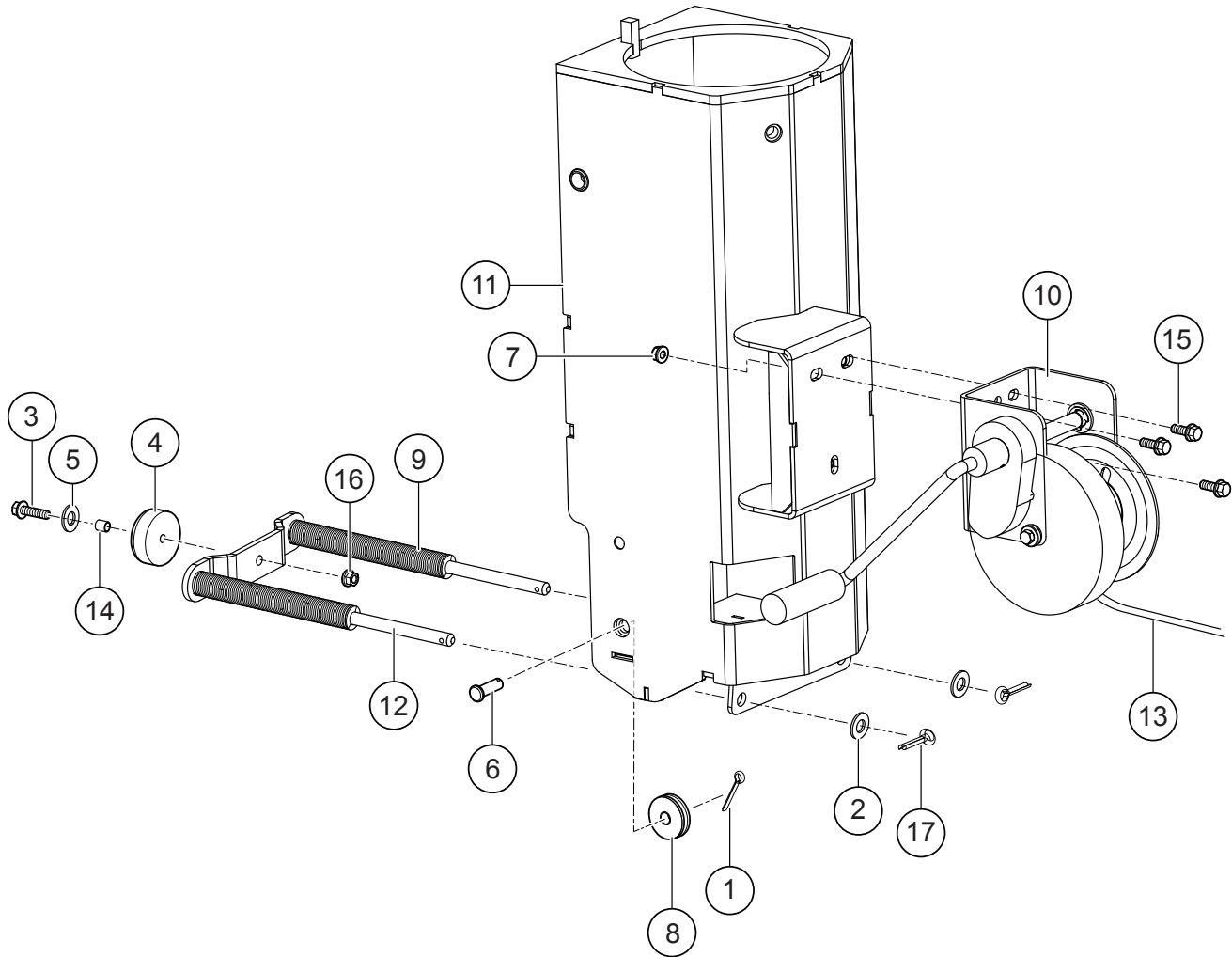

MAST BASE ASSY.

<u>NO.</u>	<u>PART NO.</u>	<u>PART NAME</u>	<u>QTY.</u>	<u>REMARKS</u>
1	0183	PIN, COTTER 1/8" D X 1-1/4"	1	
2	0447	WASHER, FLAT 1/2 SAE	2	
3	2623	SCREW, HHC 5/16-18 X 1-1/4"	1	
4	17336	BUMPER, 2.5" DIA X 1"	1	
5	19470	WASHER, FLAT 5/16 USS	1	
6	19974	PIN, CLEVIS 1/2" X 1.25" EFF	1	
7	21781	NUT, FLANGED 3/8-16 SERRATED PLTD	3	
8	29155	SHEAVE, 2.0" OD X 0.50" ID	1	
9	34362	SPRING, CENTURY D-1145	2	
10	34636	WINCH, BRAKE, 1500LB	1	
11	34742	SWIVEL BASE	1	
12	34752	SPRING MOUNT, MAST RETURN	1	
13	34794	CABLE, MAST, 3/16" X 112"	1	
14	34810	SPACER, .32" ID X .41" OD X .44" L	1	
15	38274	SCREW, HHFS 3/8-16 X .75" ZINC	3	
16	49071	NUT, FLANGED 5/16-18 SERRATED PLTD	1	
17	965103	PIN, COTTER 5/32" X 1", PLTD	2	

MAST ASSY.

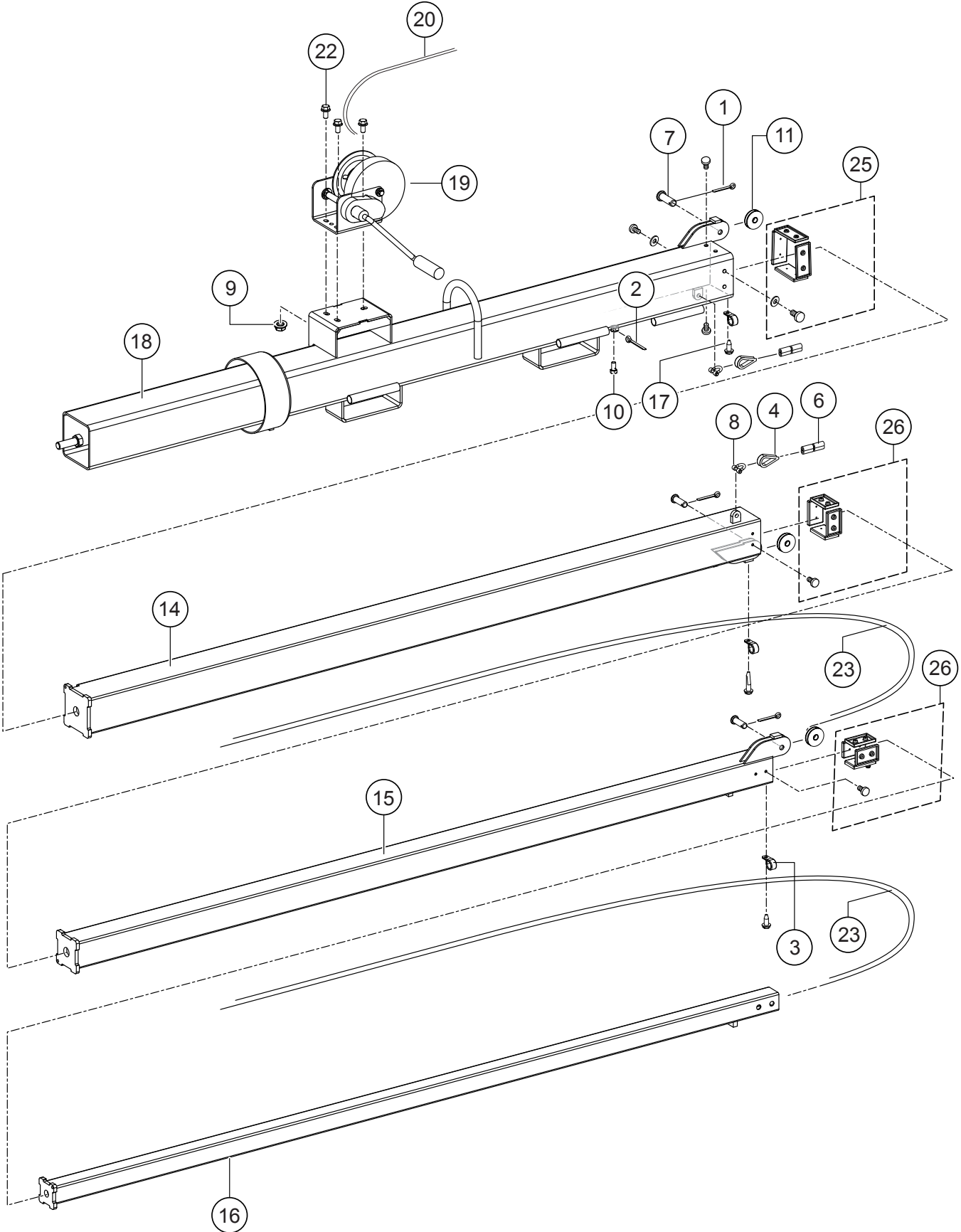

MAST ASSY.

<u>NO.</u>	<u>PART NO.</u>	<u>PART NAME</u>	<u>QTY.</u>	<u>REMARKS</u>
1	0183	PIN, COTTER 1/8"D X 1-1/4"	3	
2	6014 B	PIN, COTTER 3/32"D X 1	1	
3	8125	CLAMP, 5/8 LOOP X .406 HOLE	3	
4	19200	THIMBLE, 3/16 WIRE	3	
6	19973	SWAGE, AL 3/16	6	
7	19974	PIN, CLEVIS 1/2 X 1.25 EFF	3	
8	19975	SHACKLE, ANCHOR CP	2	
9	21781	NUT, FLANGED 3/8-16 SERRATED PLTD	3	
10	29075	SCREW, HHC 1/2-13 x DRILLED	1	
11	29155	SHEAVE, 2.00 OD X 0.500 ID	3	
14	34127	TUBE, BOTTOM SECTION	1	
15	34129	TUBE, MID SECTION	1	
16	34131	TUBE, TWR TOP	1	
17	34310	SCREW, HHF 1/4-20 X 3/8", TYPE F, ZP	3	
18	34237	MAST, BASE UNIT	1	
19	34636	WINCH, BRAKE, 1500#	1	
20	34796	CABLE ASSY. LOWER MAST, SERVICE W/CLIPS	1	
22	38274	SCREW, HHFS 3/8-16 X .75 ZINC	3	
23	34881	CABLE ASSY. KIT, MID MAST, SERVICE W/CLIPS	2	
25	34908	KIT, LOWER BLOCK	1	
26	34909	KIT, UPPER BLOCK	2	

WINCH ASSY.

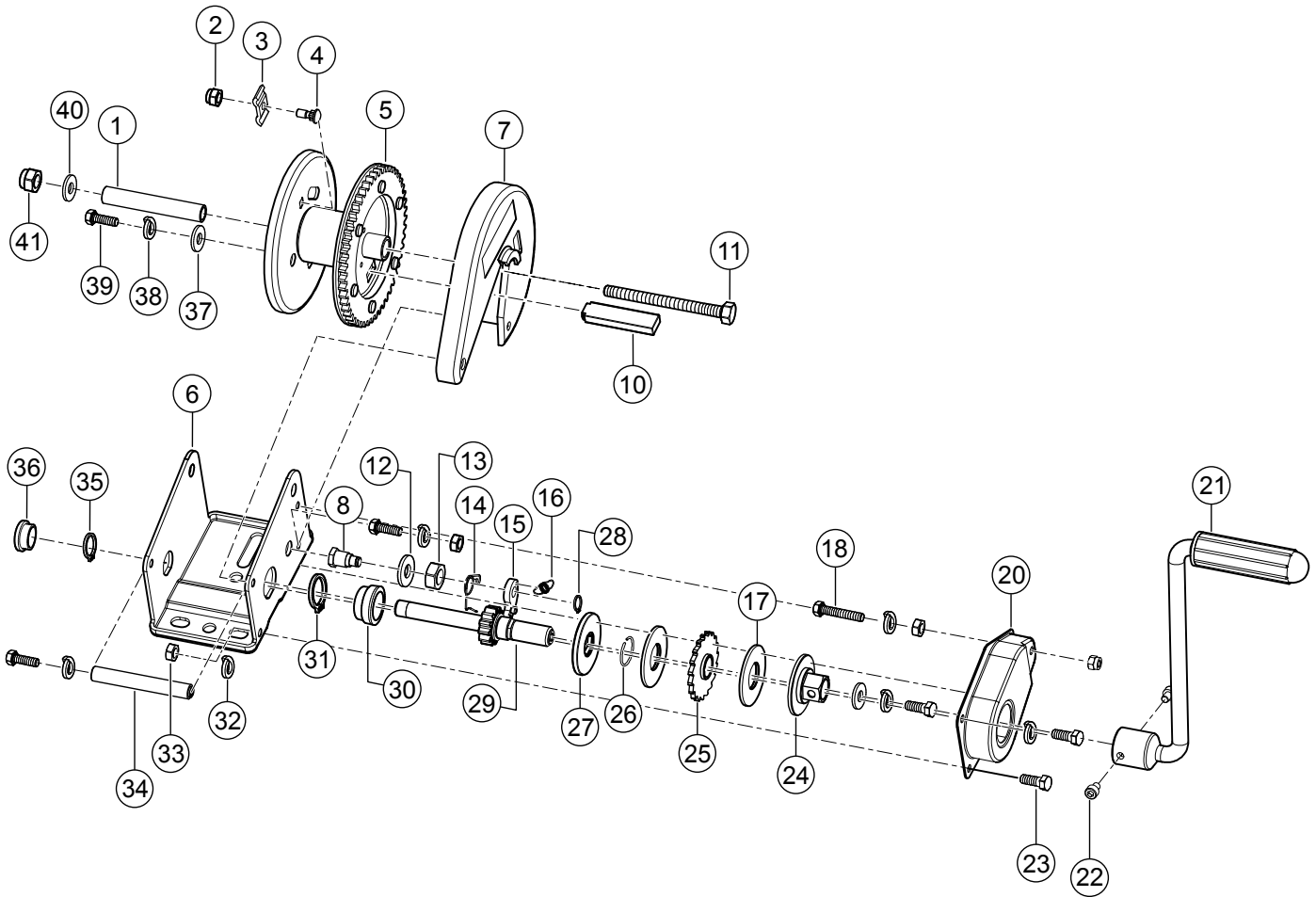

WINCH ASSY.

<u>NO.</u>	<u>PART NO.</u>	<u>PART NAME</u>	<u>QTY.</u>	<u>REMARKS</u>
1	345110-01	RETAINING SLEEVE	1	
2	345110-02	LOCK NUT M6	1	
3	345110-03	CABLE ANCHOR	1	
4	345110-04	BOLT M6 X 15	1	
5	345110-05	DRUM WELDMENT	1	
6	345110-06	BASE	1	
7	345110-07	GEAR COVER, PLASTIC	1	
8	345110-08	BOLT M6 X 25	1	
9	345110-09	PINION-JAW	1	
10	345110-10	BELT PIN	1	OPTIONAL
11	345110-11	BOLT M10 X 108	1	
12	345110-12	WAVE SPRING WASHER 12	1	
13	345110-13	NUT M12 X 1.5	1	
14	345110-14	TORSION SPRING - JAW	1	
15	345110-15	JAW	1	
16	345110-16	EXTENSION SPRING	1	
17	345110-17	BRAKE DISC	2	
18	345110-18	BOLT M6 X 30	1	
19	345110-19	WASHER 6	1	
20	345110-20	COVER-RATCHET WHEEL	1	
21	345110-21	CRANK HANDLE ASSEMBLY	1	
22	345110-22	BOLT M6 X 8	2	
23	345110-23	BOLT M6 X 12	4	
24	345110-24	BRAKE NUT	1	
25	345110-25	RATCHET ASSEMBLY	1	
26	345110-26	RETAINING RING	1	
27	345110-27	RETAINING DISC	1	
28	345110-28	CIRCLIP 8	1	
29	345110-29	BRAKE GEAR PINION	1	
30	345110-30	BUSH-BIG 20	1	
31	345110-31	CIRCLIP 26	1	
32	345110-32	SPRING WASHER 6	6	
33	345110-33	NUT M6	3	
34	345110-34	RETAINING PINION	1	
35	345110-35	SPRING RETAINER	1	
36	345110-36	BUSH-SMALL 12.8	1	
37	345110-37	WASHER(OPTIONAL)	1	
38	345110-38	SPRING WASHER(OPTIONAL)	1	
39	345110-39	BOLT M6 X 12(OPTIONAL)	1	
40	345110-40	WASHER 10	1	
41	345110-41	LOCK NUT M10	1	

T-BAR ASSY.

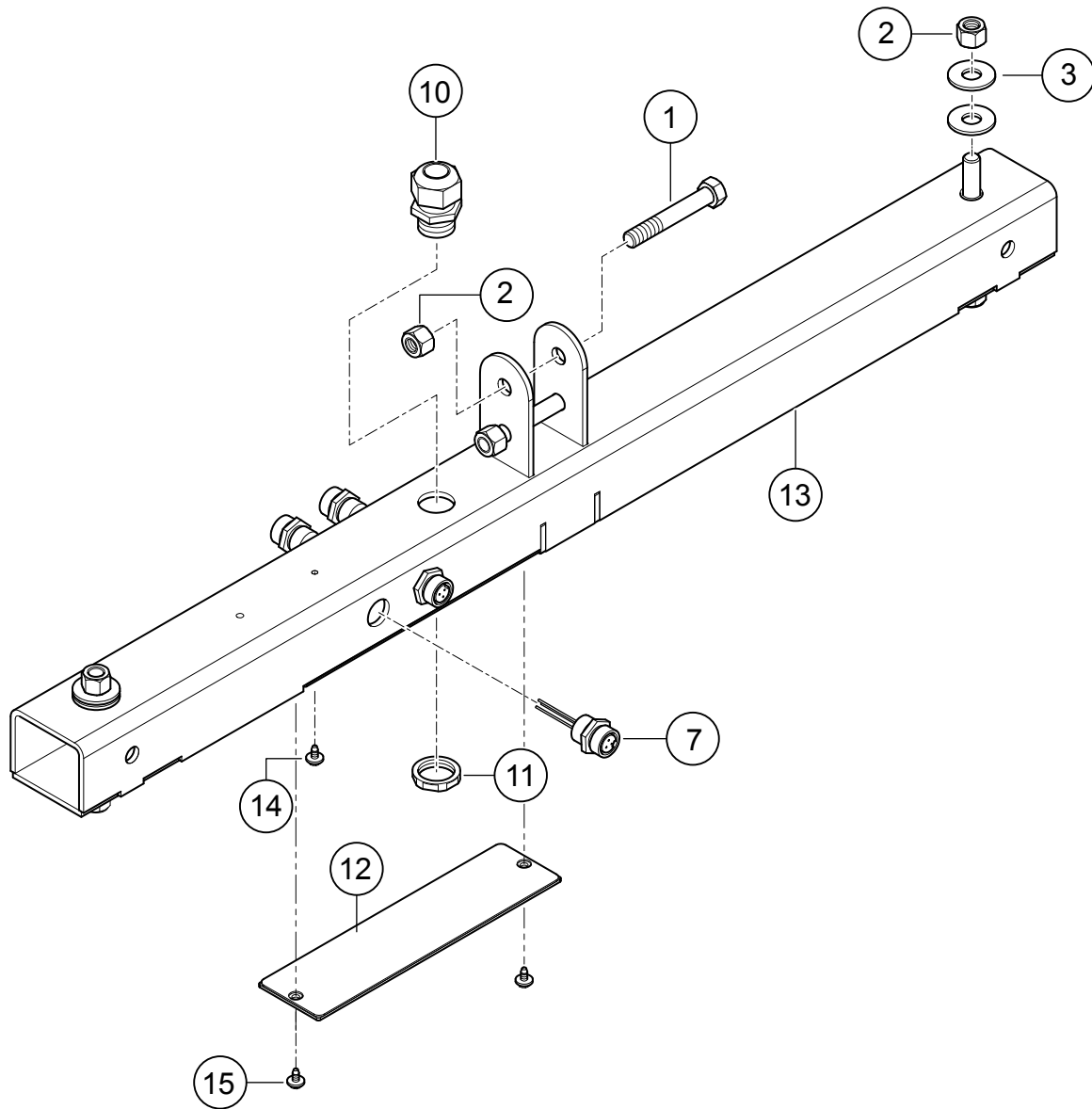

T-BAR ASSY.

<u>NO.</u>	<u>PART NO.</u>	<u>PART NAME</u>	<u>QTY.</u>	<u>REMARKS</u>
1	06503-026	SCREW, HHC 1/2-13 X 3-1/4"	2	
2	10176	NUT, NYLOC 1/2-13	6	
3	13211	WASHER, FLAT 1/2" USS	8	
7	29168	RECEPTACLE, FEM	4	
10	29655	CORDGRIP, LIQUID TIGHT, 3/4 NPT	1	
11	29656	LOCKNUT, FLANGED NYLON, 3/4 NPT	1	
12	34842	PANEL ASSY. T-BAR ACCESS W/ GASKET	1	
13	34147	T-BAR	1	
14	34305	SCREW, HHF SLOT, #10-32 X 3/8" TYPE F	1	
15	30119	SCREW, 1/4-20 X 7/8", TYPE 23, ZP, IND HEX. DOG PT.	2	

ENGINE MOUNTING

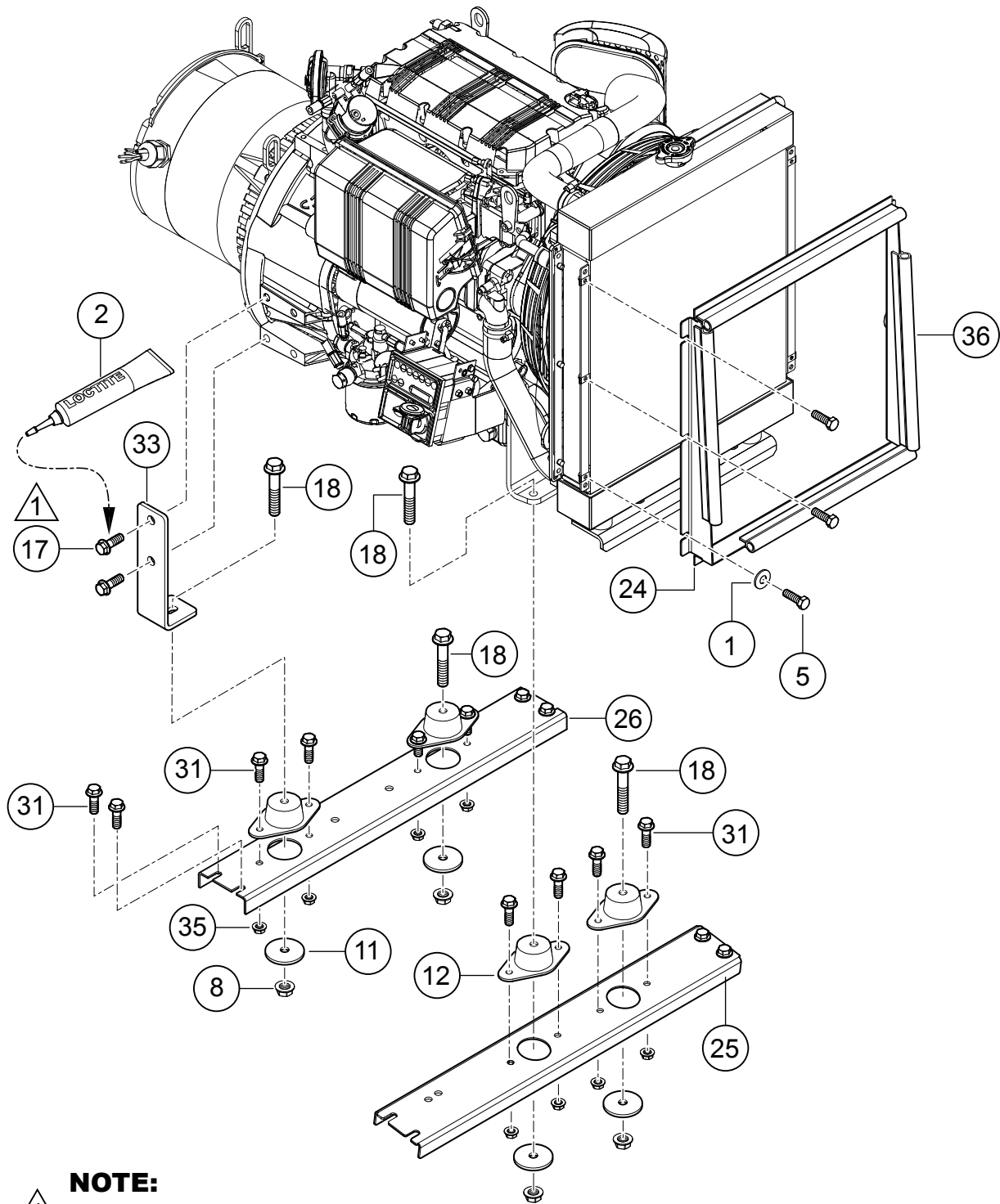

NOTE:
▲ APPLY LOCTITE # 271 RED

ENGINE MOUNTING

<u>NO.</u>	<u>PART NO.</u>	<u>PART NAME</u>	<u>QTY.</u>	<u>REMARKS</u>
1	0948	WASHER, FLAT SAE 1/4"	6	
2	19379-014	LOCTITE #271 RED	AR	
5	12464	SCREW, HHC M6-1.0 X 16MM	6	
8	21781	NUT, FLANGED 3/8-16 SERRATED PLTD	4	
11	29043-001	WHEEL, POINTER .41 ID X 2.00 OD	4	
12	29269	MOUNT, VIBRATORY ENGINE	4	
17	34317	SCREW, HHFS M12-1.75 X 20 MM	4	
18	34318	SCREW, HHFS 3/8-16 X 2-1/4"	4	
24	34685	SHROUD, RADIATOR	1	
25	34688	CROSSMEMBER, FRONT	1	
26	34689	CROSSMEMBER, REAR	1	
31	36720	SCREW, HHFS 5/16-18 X 3/4" GRD5	16	
33	49003	MOUNT, REAR ENGINE	2	
35	49071	NUT, FLANGED 5/16-18 SERRATED PLTD	8	
36	60124	GASKET, SPONGE BULB.....	5.....	1PC = 1 FT

ENGINE AND COMPONENTS

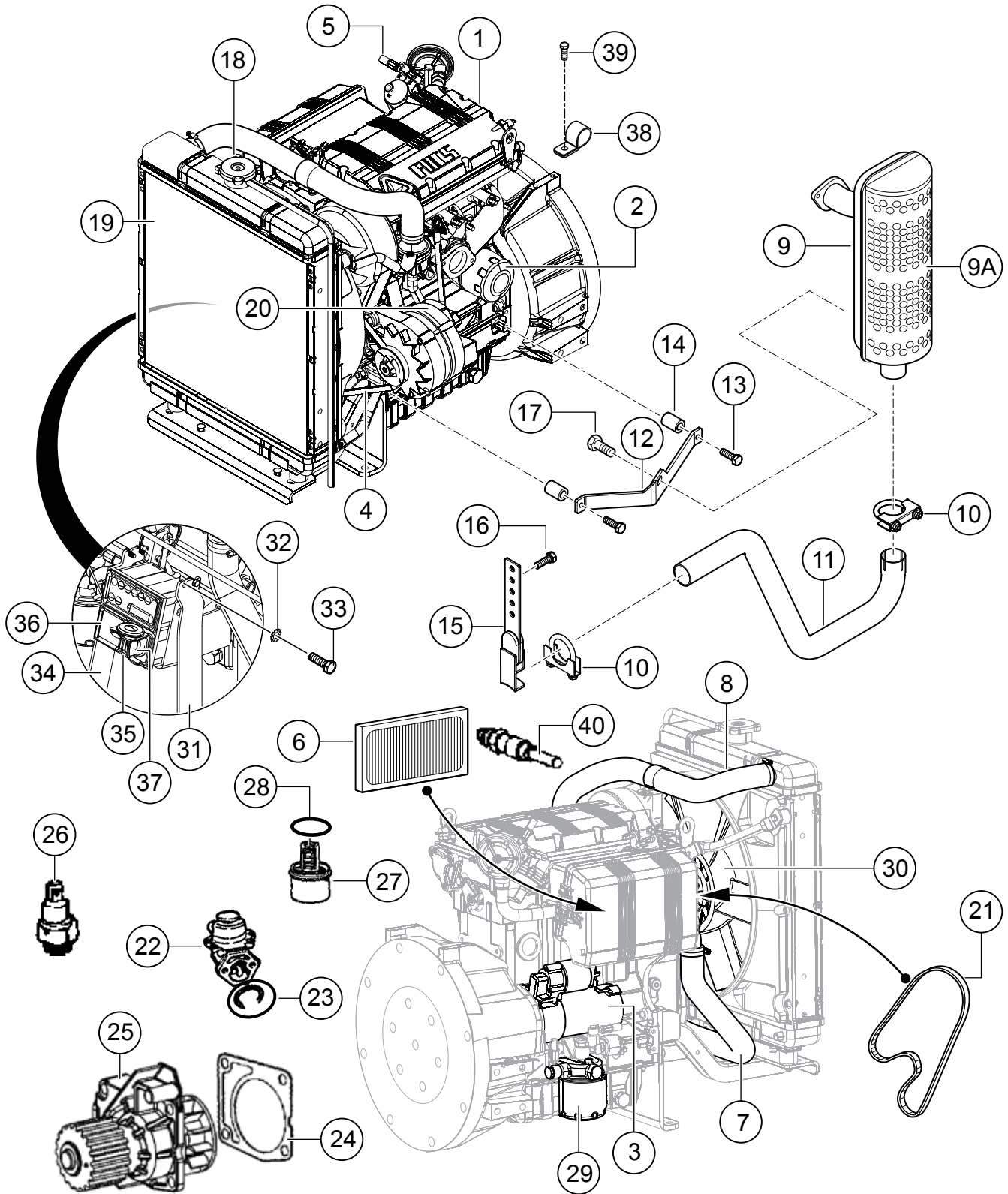

ENGINE AND COMPONENTS

<u>NO.</u>	<u>PART NO.</u>	<u>PART NAME</u>	<u>QTY.</u>	<u>REMARKS</u>
1	29644	ENGINE, KOHLER KDW1003/L FOCS	1	
2	ED0021752830S	OIL FILTER	1	
3	ED0058402240S	STARTER ASSY.	1	
4	ED0024403200S	FAN BELT 835 MM	1	
5	19761	TERMINAL, SPLICE 16-14	1	
6	ED0021751640S	CARTRIDGE, AIR FILTER	1	
7	ED0054011950S	HOSE, RADIATOR, LOWER	1	
8	ED0054011940S	HOSE, RADIATOR, UPPER	1	
9	ED0054604500S	MUFFLER	1	
9A	ED0069271720S	GUARD, MUFFLER	1	
10	10855	CLAMP, 1-1/2" MUFFLER	2	
11	34215	TAIL PIPE EXTENSION	1	
12	29937	BRACE, LOWER MUFFLER	1	
13	23792	SCREW, HHFS M8-1.25 X 30 MM	2	
14	29938	SPACER, MUFFLER BRACKET	2	
15	34335	HANGER, EXHAUST	1	
16	49048	SCREW, HHFS 1/4-20 X 3/4" GRD5	2	
17	2299	BOLT, M8-1.25 X 16 MM	1	
18	ED0090002390S	RADIATOR CAP	1	
19	ED0073503220S	RADIATOR	1	
20	ED0011573910S	ALTERNATOR	1	
21	ED0024403380S	TIMING BELT	1	
22	ED0065851510S	PUMP, FUEL FEED	1	
23	ED0012000870S	O-RING, FEED PUMP	1	
24	ED0065844380S	WATER PUMP	1	
25	ED0045802150S	GASKET, WATER PUMP	1	
26	ED0067450560S	OIL PRESSURE SWITCH	1	
27	ED0091951240S	THERMOSTAT	1	
28	ED0012000910S	O-RING, THERMOSTAT	1	
29	ED0021752880S	FUEL FILTER	1	
30	ED0097183240S	COOLING FAN	1	
31	34814	MOUNT, RIGHT ENG. CONTROL BOX	1	
32	10237	WASHER, EXT. SHKP, #10	4	
33	34823	SCREW, HHC M5-.8 X 12 MM, 8.8 DIN	4	
34	34813	MOUNT, LEFT ENG. CONTROL BOX	1	
35	ED34001S	KEY, IGNITION, DOUBLE SIDED	1	
36	ED0072454650S	CONTROL PANEL	1	
37	ED0050412980S	IGNITION SWITCH	1	
38	8125	CLAMP, HOSE SUPPORT 5/8"	1	
39	22021	SCREW, HEX M8-1.25 X 20 MM GRD10.9	1	
40	ED0021000890S	GLOW PLUG	3	

TUB/TRAILER ASSY.

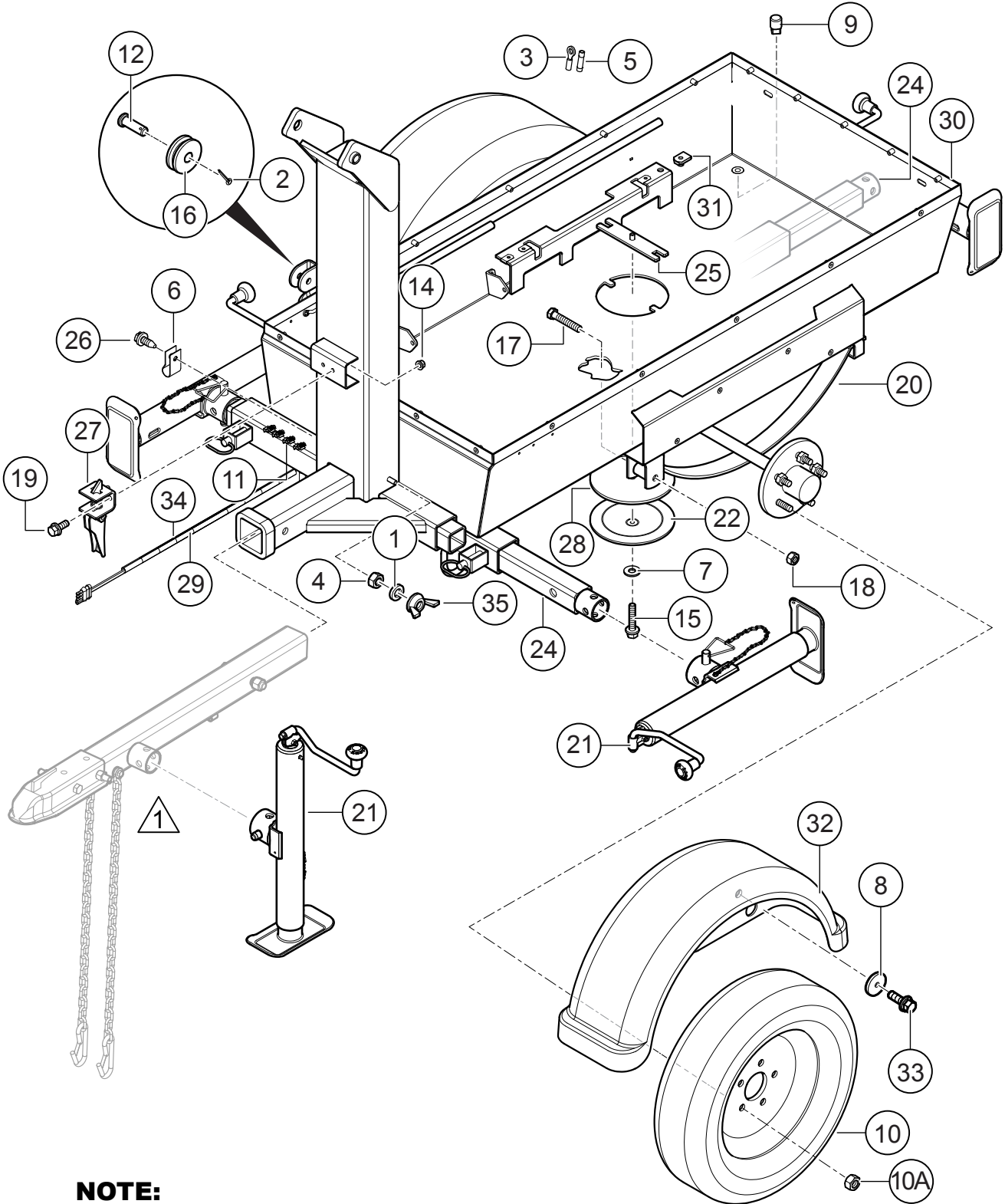

NOTE:

1 SEE TONGUE ASSY. FIGURE

TUB/TRAILER ASSY.

<u>NO.</u>	<u>PART NO.</u>	<u>PART NAME</u>	<u>QTY.</u>	<u>REMARKS</u>
1	0166 A	WASHER, LOCK, 3/8" MED.	1	
2	0183	PIN, COTTER 1/8"D X 1-1/4"	1	
3	1319	TERMINAL, RING 16-14 1/4" LOOP	1	
4	1876	NUT, HEX JAM 3/8-16 CLASS 2B	1	
5	2540	CONNECTOR, BUTT SPLICE, 16-14	1	
6	8126	CLAMP, HOSE 1/2" LOOP X 1/4" HOLE	1	
7	34640	WASHER, SEALING, 5/16 X 3/4	1	
8	10930	WASHER, FENDER, 1/4 X 1-1/4"	8	
9	16185	FITTING, PLUG 1/4MP SQ HD	1	
10	19045	WHEEL/TIRE ST175/80-13 L.R. C 5-LUG	2	
10A	29184	NUT, LUG 1/2-20	10	
11	19761	TERMINAL, SPLICE 16-14 CLOSED, BLUE	4	
12	19974	PIN, CLEVIS 1/2 X 1-1/4" EFF	1	
14	49071	NUT, FLANGED 5/16-18 SERRATED PLTD	2	
15	21906	SCREW, HHFS 5/16-18 X 1-1/2" GRD5	1	
16	29155	SHEAVE, 2.00" OD X 0.50" ID	1	
17	29248	SCREW, HHC 9/16-18 X 3"	2	
18	29249	NUT, 9/16-18 N-2	2	
19	9091	SCREW, HHFS 5/16-18 X 1" GRD5	2	
20	34015	AXLE, ASSY.	1	
21	34093	JACK, 2000#, 10" TOP WIND	4	
22	34101	COVER, ACCESS PANEL	1	
24	34197	OUTRIGGER	3	
25	34213	BRACKET, ACCESS COVER MOUNT	1	
26	34310	SCREW, HHF 1/4 - 20 X 3/8", TYPE 23, ZP	1	
27	34331	LATCH, MAST	1	
28	34378	GASKET, ACCESS COVER	1	
29	34604	HARNES, 25' 4 FLAT TRAILER END	1	
30	34659	TUB/FRAME	1	
31	35358	NUT, "U" TYPE, 5/16-18	24	
32	34720	FENDER	2	
33	49048	SCREW, HHFS 1/4-20 X 3/4" GRD5	8	
34	60221	LOOM, .375 SPLIT	5	1PC = 1 FT
35	W29109	NUT, WING 3/8-16	1	

TONGUE ASSY.

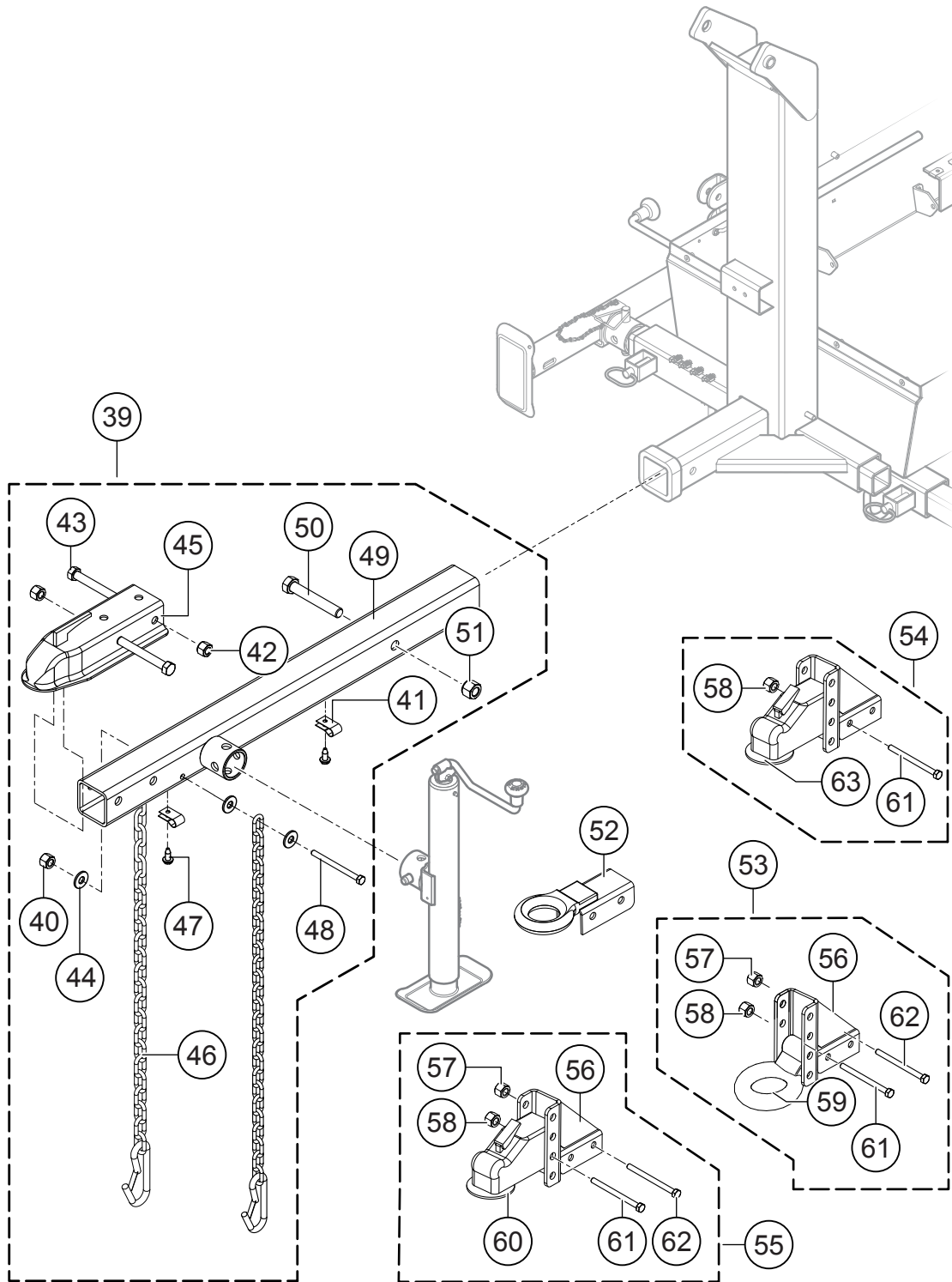

TONGUE ASSY.

<u>NO.</u>	<u>PART NO.</u>	<u>PART NAME</u>	<u>QTY.</u>	<u>REMARKS</u>
39	34681	TOUNGE ASSY.....	1.....	INCLUDES ITEMS W/\$
40\$	5283	NUT, NYLOC 5/16-18	1	
41\$	8126	CLAMP, HOSE 1/2" LOOP X .25" HOLE	2	
42\$	10176	NUT, NYLOC 1/2-13	2	
43\$	16521	SCREW, HHC 1/2-13 X 4" GRD8	2	
44\$	19470	WASHER, FLAT 5/16" USS	4	
45\$	29546	COUPLER, 2" BALL 2.50" TUBE	1	
46\$	34005	CHAIN, SAFETY	2	
47\$	34310	SCREW, HHF, 1/4-20 X 3/8," TYPE 23, ZP	2	
48\$	34370	SCREW, HHC 5/16-18 X 4.0" GRD8	1	
49\$	34680	HITCH TUBE	1	
50\$	915319	SCREW, HHC 5/8-11 X 4" GRD8 YZ	1	
51\$	9503	NUT, NYLOC 5/8-11	1	
52	29791	HITCH, PINTLE FIXED (OPTION)	1	
53	29721	HITCH, PINTLE KIT, ADJ. HEIGHT (OPTION).....	1.....	INCLUDES ITEMS W/\$
54	29720	HITCH BALL, 2" ADJ. HEIGHT (OPTION)	1.....	INCLUDES ITEMS W/%
55	34812	HITCH BALL KIT, 2-5/16" ADJ. HEIGHT (OPTION)	1.....	INCLUDES ITEMS W/#
56\$#%	29718	COUPLER ADAPTER	1	
57\$#	10176	NUT, NYLOC 1/2-13	2	
58\$#%	9503	NUT, NYLOC 5/8-11	2	
59\$	29369	PINTLE EYE, ADJUSTABLE	1	
60#	34811	COUPLER, 2-5/16" BALL, ADJUSTABLE	1	
61\$#	915218	SCREW, HHC 1/2-13 X 3-3/4" GRD8	2	
62\$#%	9502	SCREW, HHC 5/8-11 X 4-1/2" GRD8	2	
63%	29228	COUPLER, 2" BALL, ADJUSTABLE	1	

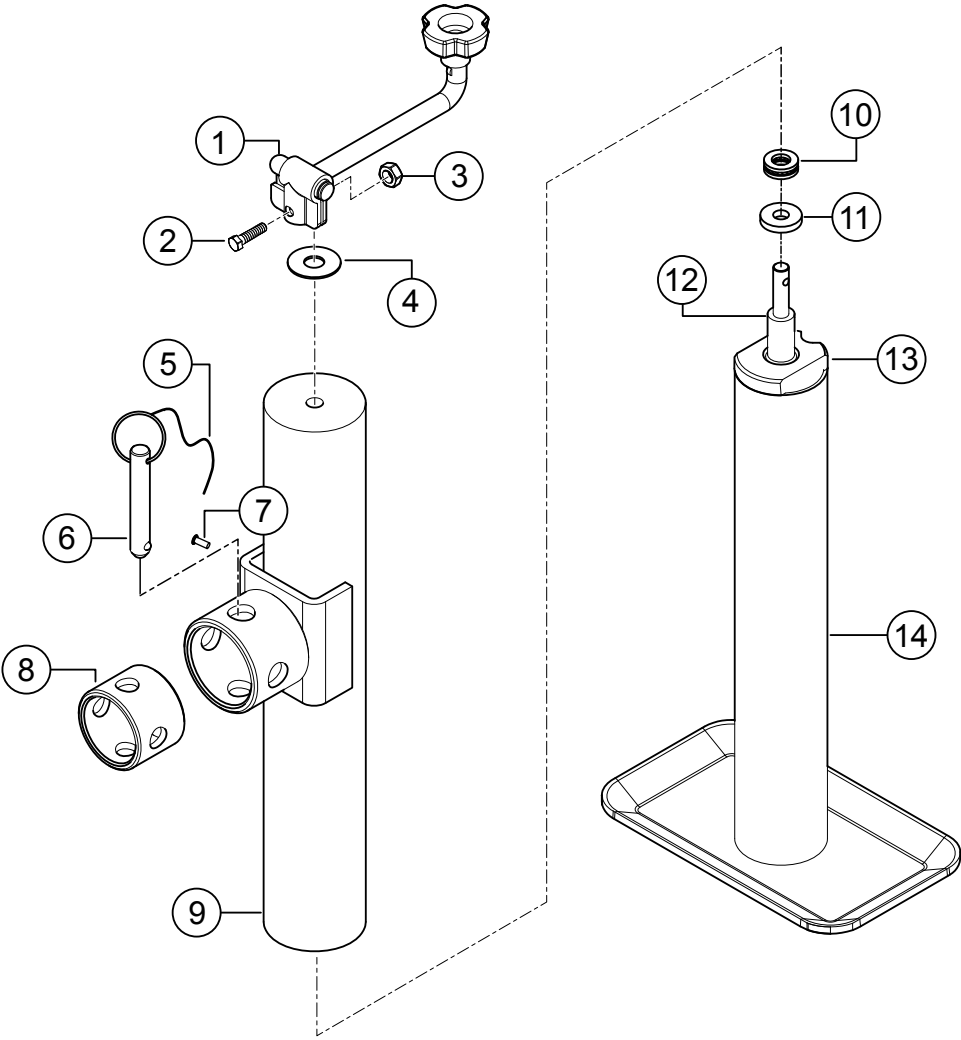

JACK ASSY.

<u>NO.</u>	<u>PART NO.</u>	<u>PART NAME</u>	<u>QTY.</u>	<u>REMARKS</u>
1	345109-01	HANDLE ASSEMBLY	1	
2	345109-02	BOLT M6X28	1	
3	345109-03	LOCK NUT M6	1	
4	345109-04	WASHER	1	
5	345109-05	CHAIN	1	
6	345109-06	PIN	1	
7	345109-07	CHAIN RIVET	1	
8	345109-08	MALE MOUNT TUBE	1	
9	345109-09	OUTER TUBE ASSEMBLY	1	
10	345109-10	BEARING	1	
11	345109-11	HEATED WASHER	1	
12	345109-12	THREAD	1	
13	345109-13	MAIN NUT	1	
14	345109-14	INNER TUBE	1	

GENERATOR ASSY.

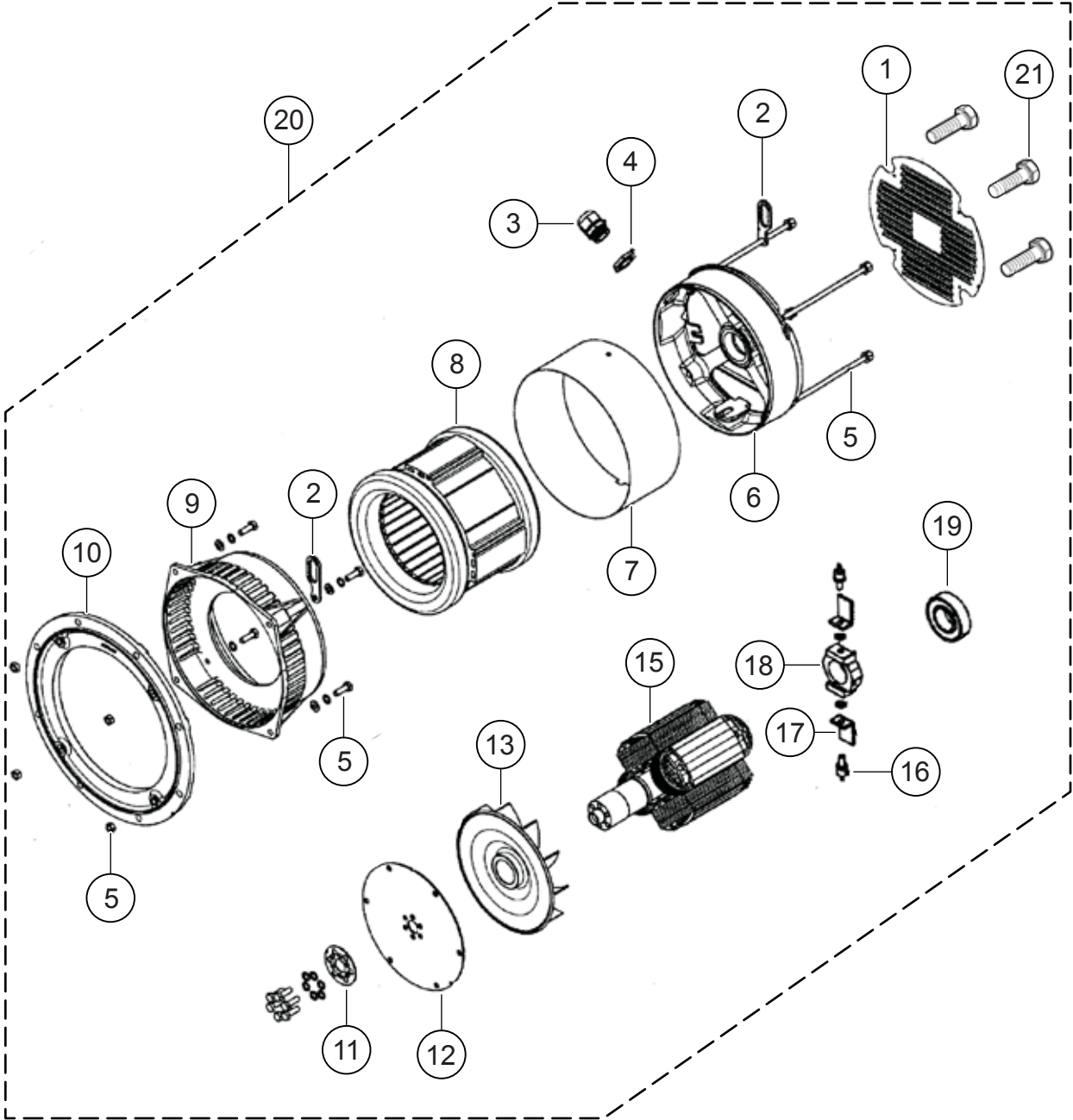

NOTES:

SEE CONTROL PANEL ASSY. FOR EXCITATION CAPACTIOR

GENERATOR ASSY.

<u>NO.</u>	<u>PART NO.</u>	<u>PART NAME</u>	<u>QTY.</u>	<u>REMARKS</u>
1%	9903905068	REAR SEAL	1	
2%	9903905069	LIFTING HOOK	2	
3%	9909510155	PG21 CABLE GLAND	1	
4%	9909510195	PG21 NUT	1	
5%	GELT3100ROD	COVER STAY BOLT AND NUT	4	
6%	6102204175	NON-DRIVE END BRACKET	1	
7%	GELT3ENCBAND	ENCLOSING BAND	1	
8%	GELT3100STATOR60	WOUND STATOR AND FRAME	1	
9%	6102208192	DRIVE END BRACKET	1	
10%	6102208193	INTERCHANGEABLE FLANGE	1	
11%	6110611508	RING SPACER	1	
12%	GEECO3DISC65	FLEXIBLE DISC	1	
13%	7502223039	FAN	1	
15%	GELT3100ROTOR60	ROTOR ASSY	1	
16%	9910359005	DIODES	2	
17%	7501001015	HEAT SINK, ROTATING DIODE BRIDGE	2	
18%	9909527011	SUPPORT, ROTATING DIODE BRIDGE	1	
19%	9900905055	REAR BEARING 6205-2RS	1	
20	29895	GENERATOR	1	INCLUDES ITEMS W/%
21%	29895SCREW	COVER SCREWS, SET OF 3	1	

BATTERY ASSY.

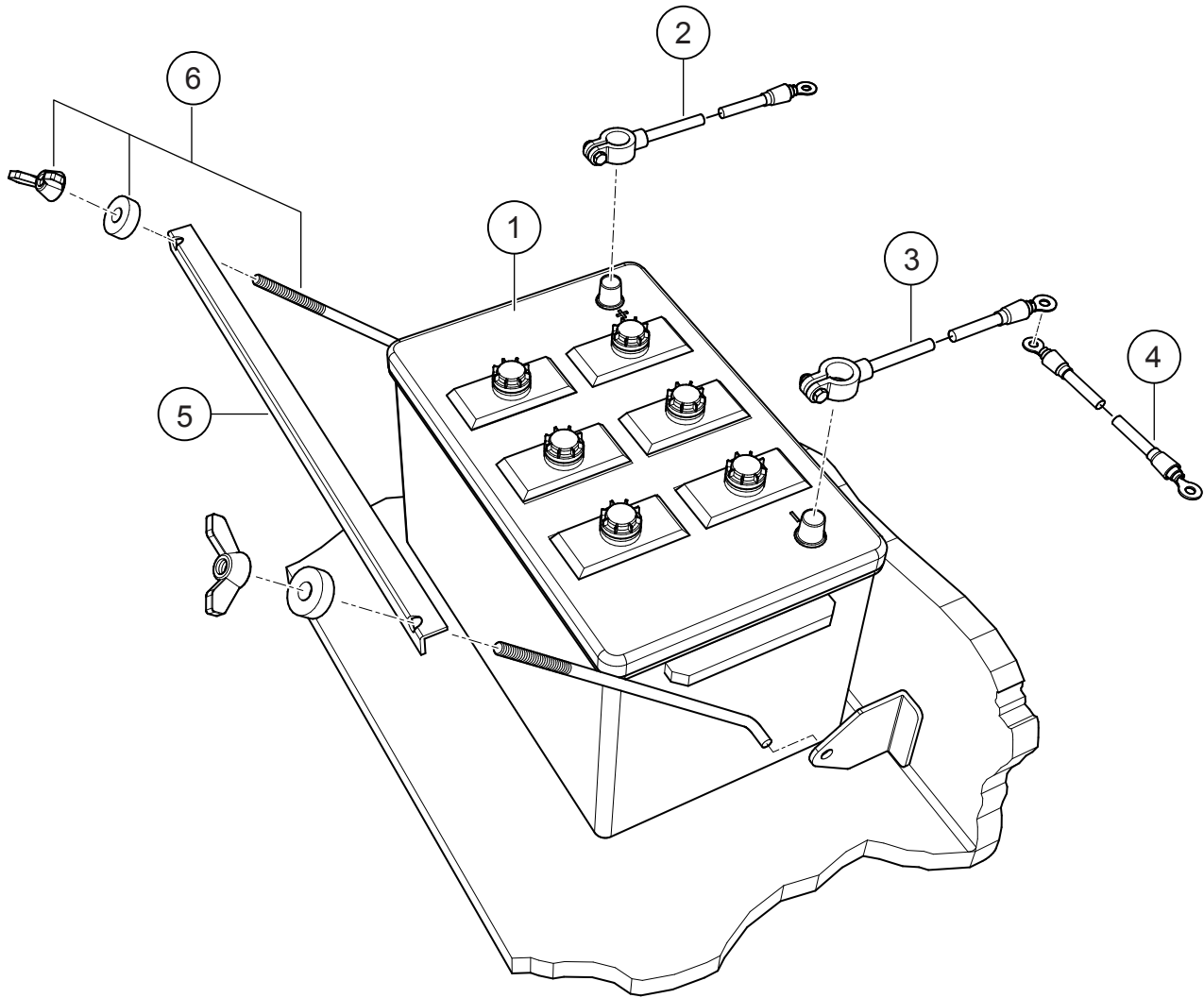

BATTERY ASSY.

<u>NO.</u>	<u>PART NO.</u>	<u>PART NAME</u>	<u>QTY.</u>	<u>REMARKS</u>
1	10315	BATTERY, 12V GROUP 24 WET	1	
2	34393	CABLE, BATTERY POS 4GA X 48" POST	1	
3	34392	CABLE, BATTERY NEG 6GA X 20" POST	1	
4	34394	CABLE, BATTERY CHASSIS GROUND	1	
5	34759	BATTERY HOLD DOWN	1	
6	34900	BOLT-J, W/ HDWR	2	

COIL CORD ASSY.

CONNECT TO T-BAR ASSEMBLY

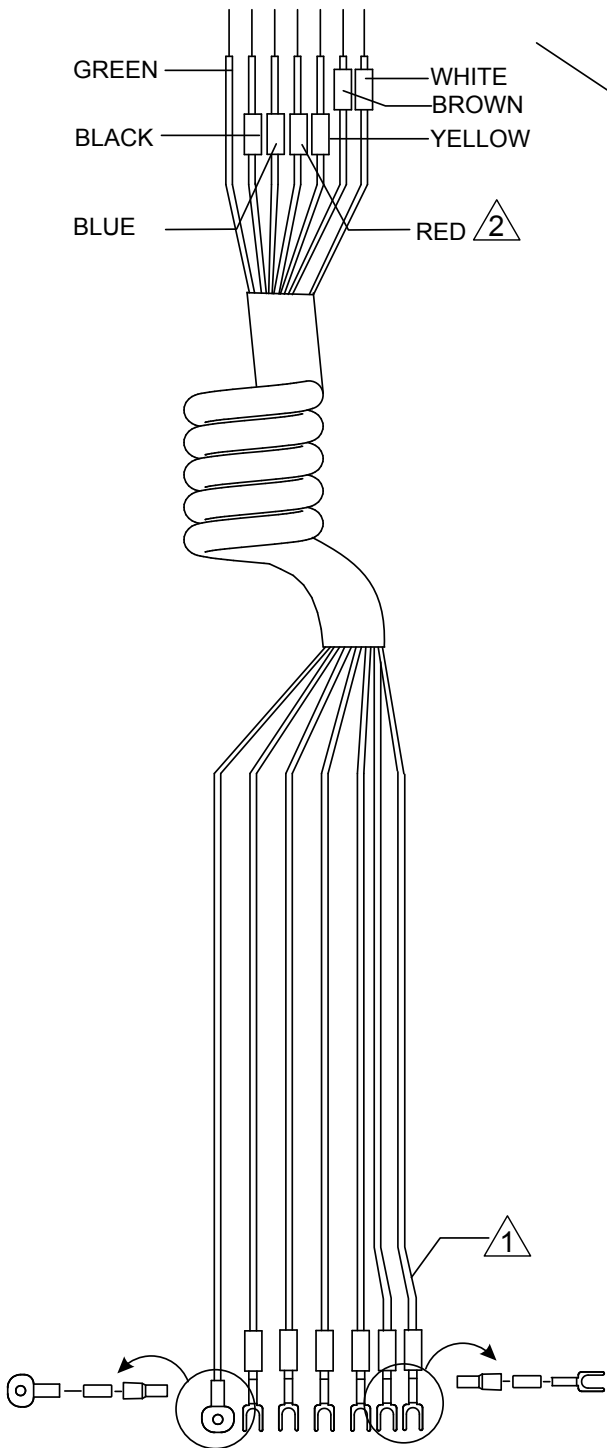

CONNECT TO BALLAST
BOX OUTPUT

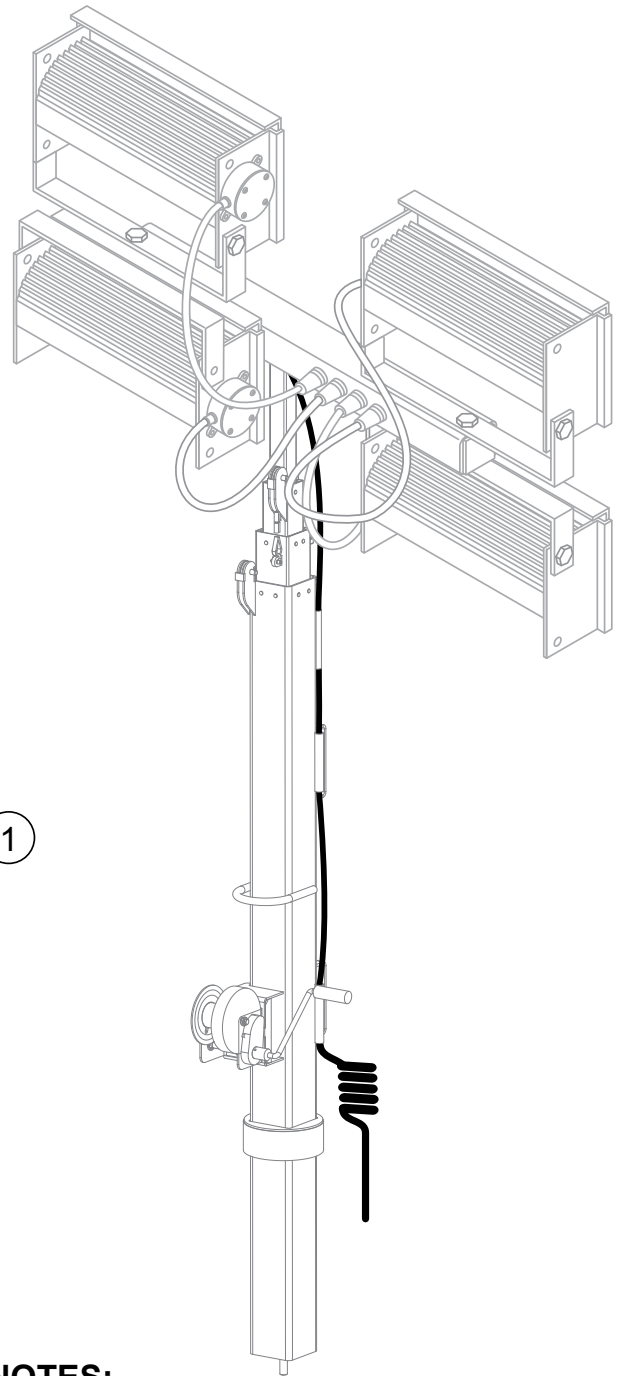

NOTES:

- ① CONNECT THIS END OF COIL CORD ASSY. TO BALLAST BOX. REFERENCE ELECTRICAL SCHEMATIC DIAGRAM IN OPERATION MANUAL.
- ② CONNECT THIS END OF COIL CORD ASSY. TO T-BAR ASSY. REFERENCE ELECTRICAL SCHEMATIC DIAGRAM IN OPERATION MANUAL.

COIL CORD ASSY.

<u>NO.</u>	<u>PART NO.</u>	<u>PART NAME</u>	<u>QTY.</u>	<u>REMARKS</u>
1	34880	COIL CORD ASSY.....	1	INCLUDES ITEMS W/#

LAMP ASSY.

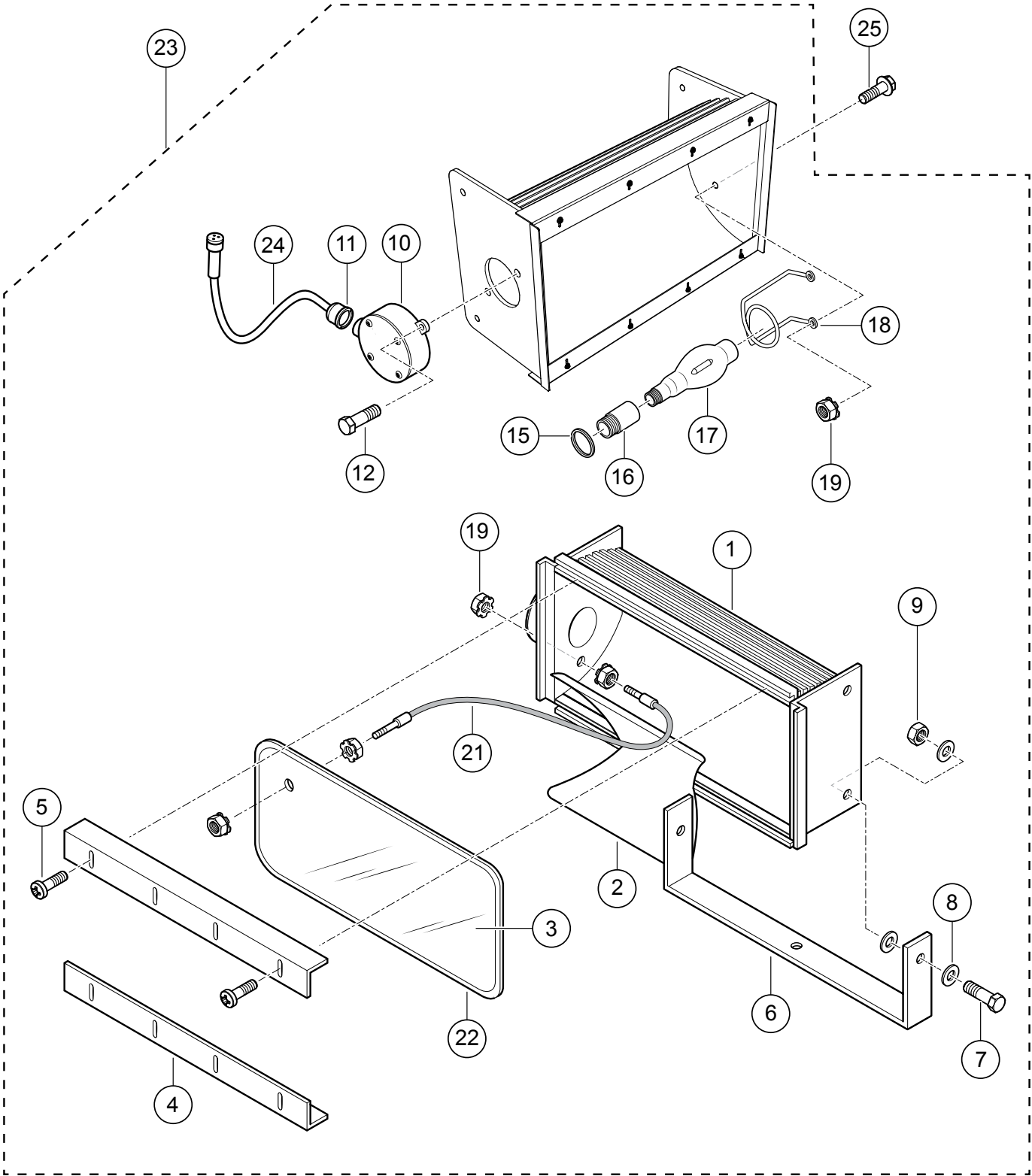

LAMP ASSY.

<u>NO.</u>	<u>PART NO.</u>	<u>PART NAME</u>	<u>QTY.</u>	<u>REMARKS</u>
1%	20S-REF-1	REF1000 BODY ASSY.	1	
2%	30M-REF-REF	REFLECTOR, ALUMINUM	1	
3%	190ZQREF	REF 1000 LENS	1	
4%	170M-REF-5	REF LENS HOLD DOWN	2	
5%	70Z-FSCR3	SCREW 8-32 X 1/2"	8	
6%	250-REF-6	YOKE, LIGHT FIXTURE	1	
7%	260Z-FSCR9	BOLT, HEX HEAD 1/2-13 x 1-1/2"	2	
8%	280Z-FWFL2	WASHER, FLAT 1/2"	4	
9%	270Z-FNT4	NUT, HEX 1/2-13	2	
10%	Z-C-239	VAPORTITE OCTAGON BOX 1/2" W/4 THREADED PLUGS G9 SILVER	1	
11%	150Z-FSR3	STRAIN RELIEF SRW 1/2" BLACK	1	
12%	Z-FSCR9	BOLT, HEX HD, 1/2-13 X 1-1/2" ZN PLT.	2	
15%	90Z-G-102	GASKET, HEX #5 OR #6	1	
16%	70Z-SK65	SOCKET, MOGUL W/GASKET	1	
17%	MVR1000BT37	BULB, LIGHT FIXTURE	1	
18%	50Z-D-REF-SUP	SUPPORT, REF1000 LAMP TIP	1	
19%	230Z-FNTL6-1	KEEPER NUT #8-32	6	
21%	210S-CBL-6	CABLE ASSEMBLY	1	
22%	200ZG106	GASKET, U-CHANNEL REFLECTOR	1	
23	29773	LIGHT FIXTURE ASSY.....	1	INCLUDES ITEMS W/%
24%	150Z-EZ67	POWER CORD, 60" W/ 3-PIN MALE PLUG	1	
25	4106781000	SCREW, 8-32 X 3/8"	2	

CONTROL PANEL ASSY.

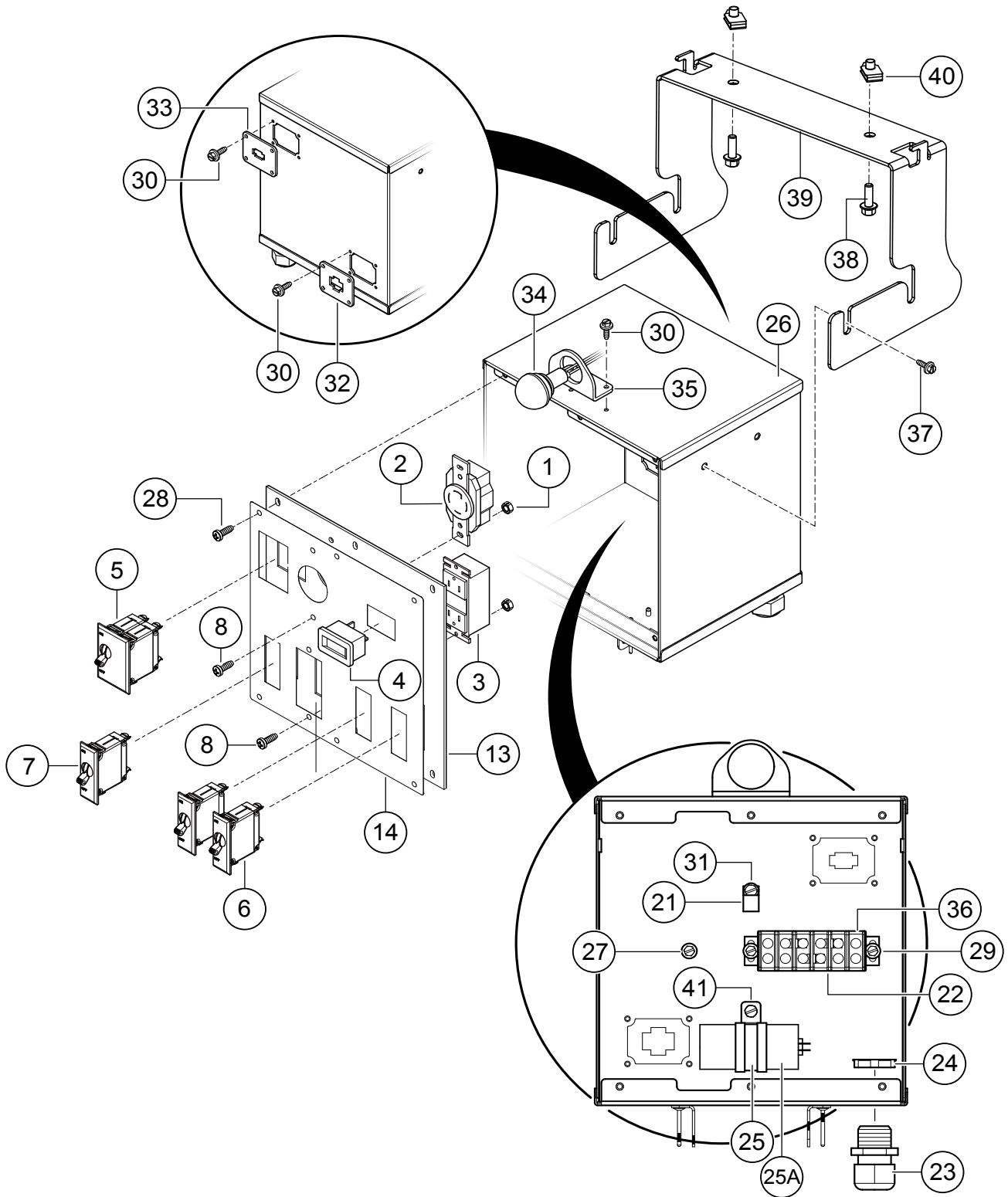

CONTROL PANEL ASSY.

<u>NO.</u>	<u>PART NO.</u>	<u>PART NAME</u>	<u>QTY.</u>	<u>REMARKS</u>
1	10019	NUT NYLOC #10-32	4	
2	29276	RECEPTACLE. 4PRG LOCKING, NEMA L-14-30R	1	
3	29343	RECEPTACLE, GFCI DUPLEX, 15A, UL/CSA	1	
4	29640	HOUR METER, SENDEC RECT FLUSH MOUNT	1	
5	34096	CIRCUIT BREAKER, 30A, UL/CSA	1	
6	34097	CIRCUIT BREAKER, 20A, UL/CSA	2	
7	34098	CIRCUIT BREAKER, 15A, UL/CSA	1	
8	34306	SCREW, PHP, # 10-32 X 5/8", TYPE F, ZP	4	
13	34360	CONTROL PANEL	1	
14	34361	DECAL, CONTROL PANEL	1	
21	11505	CLAMP, HOSE SUPT. 1/2" L	1	
22	34833	JUMPER, T8345 TERMINAL BLOCK, #10 SCREW	3	
23	29655	CORDGRIP, LIQUID TIGHT, 3/4 NPT	1	
24	29656	LOCKNUT, FLANGED NYLON, 3/4 PT	1	
25	59005	CLAMP, CUSH. LOOP, 2.0" DIA X .53" HO	1	
25A	59006	EXCITATION CAPACITOR 25uF @ 450V	1	
26	34165	CONTROL BOX	1	
27	34305	SCREW, HHF SLOT #10-32 X 3/8", TYPE F, GRN ZN	1	
28	34306	SCREW, PHP #10-32 X 5/8", TYPE F, ZP	6	
29	34308	SCREW, HHF SLOT #10-32 X 5/8", TYPE F, ZP	2	
30	34309	SCREW, HHF SLOT #10-32 X 3/8", TYPE F, ZP	10	
31	34310	SCREW, HHF 1/4-20 X 3/8", TYPE 23, ZP	1	
32	34327	MOLEX 6 PLC MTG. PLATE	1	
33	34328	MOLEX 2 PLC MTG. PLATE	1	
34	34347	LAMP, COMPACT COURTESY, 2 WIRE	1	
35	34358	MOUNT, COURTESY LAMP	1	
36	34804	TERMINAL STRIP, 6 GANG, 2 ROW #10	1	
37	34307	SCREW, HHF SLOT, 1/4-20 X 5/8", TYPE 23, ZP	4	
38	49048	SCREW, HHFS 1/4-20 X 3/4" GRD5	2	
39	34758	BRACKET, CONTROL BOX MOUNTING	1	
40	11534	NUT, "U" TYPE, 1/4-20	2	
41	49048	SCREW, HHFS 1/4-20 X 3/4" GRD 5	1	

FUEL TANK, HOSES AND MOUNTING ASSY.

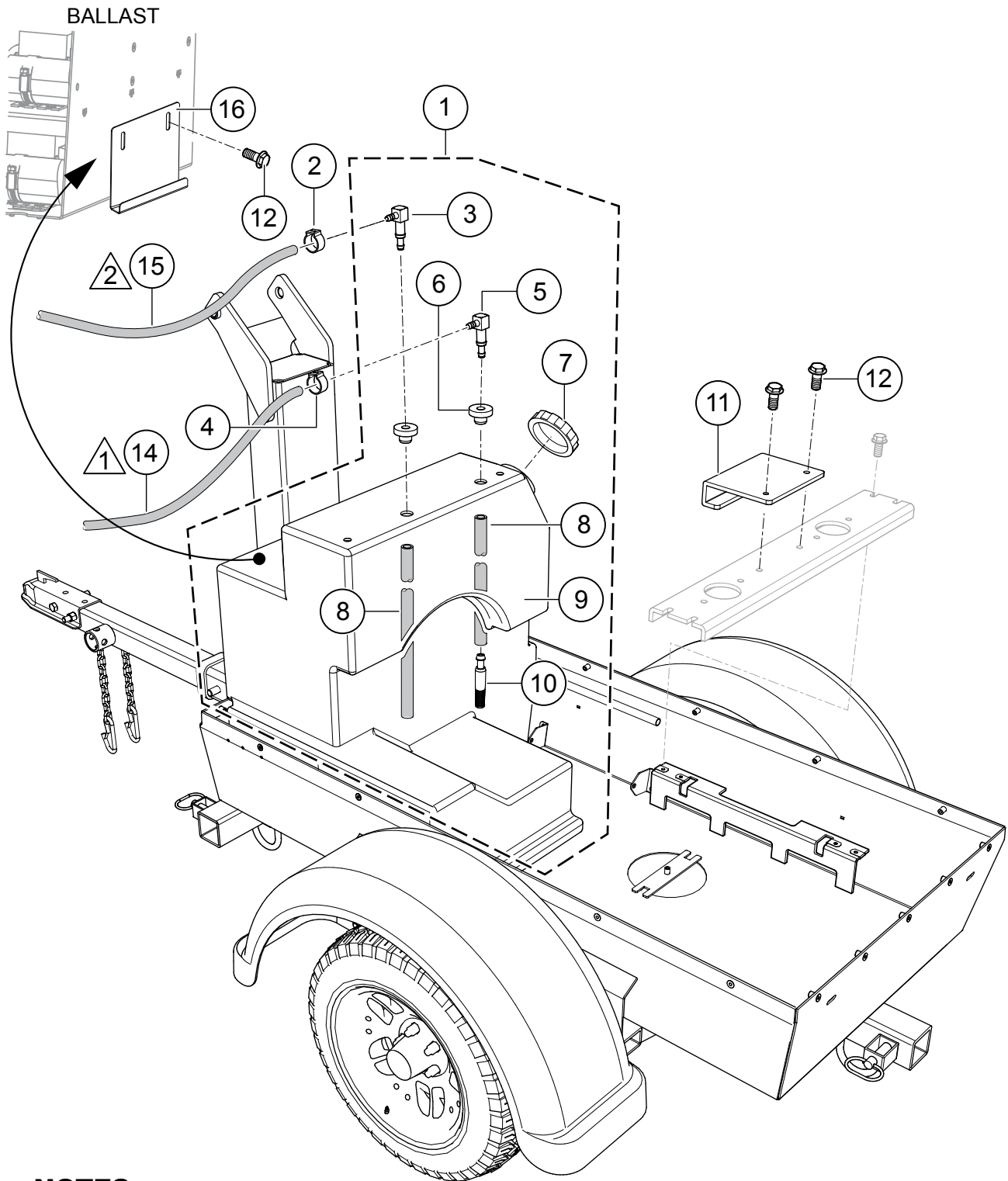

NOTES:

- ① CONNECTS TO FUEL PUMP **SUCTION SIDE**
- ② CONNECTS TO **FUEL RETURN**

FUEL TANK, HOSES AND MOUNTING ASSY.

<u>NO.</u>	<u>PART NO.</u>	<u>PART NAME</u>	<u>QTY.</u>	<u>REMARKS</u>
1	34738	FUEL TANK ASSY.....	1.....	INCLUDES ITEMS W/\$
2	22066	CLAMP, STEPLESS EAR 3/16" HOSE	1	
3\$	12007	FITTING, 90° 4SBARB X 6-4SBARB	1	
4	22067	CLAMP, STEPLESS EAR 1/4" HOSE	1	
5\$	12006	FITTING, 90° 3MBARB X 6-4SBARB	1	
6\$	19633	BUSHING, RUBBER FUEL	2	
7\$	29694	CAP, FUEL W/LANYARD, KELCH 3-1/2"	1	
8\$	60058	HOSE, .25 YELLOW PVC, 30" L EACH.....	5.....	1PC = 1FT
9\$	34719	TANK, FUEL	1	
10\$	12009	FILTER, IN-TANK	1	
11	34716	BRACKET, FUEL TANK, LOWER	1	
12	49048	SCREW, HHFS 1/4-20 X 3/4" GRD5	4	
14	60013	HOSE, FUEL Ø.250 LOW PERM 50 PSI	3.....	1PC = 1FT
15	60004	HOSE, FUEL Ø.1875 LOW PERM 50 PSI 5.5'..	6.....	1PC = 1FT
16	34836	BRACKET, FUEL TANK, UPPER	1	

TERMS AND CONDITIONS OF SALE — PARTS

PAYMENT TERMS

Terms of payment for parts are net 30 days.

FREIGHT POLICY

All parts orders will be shipped collect or prepaid with the charges added to the invoice. All shipments are F.O.B. point of origin. Multiquip's responsibility ceases when a signed manifest has been obtained from the carrier, and any claim for shortage or damage must be settled between the consignee and the carrier.

MINIMUM ORDER

The minimum charge for orders from Multiquip is \$15.00 net. Customers will be asked for instructions regarding handling of orders not meeting this requirement.

RETURNED GOODS POLICY

Return shipments will be accepted and credit will be allowed, subject to the following provisions:

1. A Returned Material Authorization must be approved by Multiquip prior to shipment.
2. To obtain a Return Material Authorization, a list must be provided to Multiquip Parts Sales that defines item numbers, quantities, and descriptions of the items to be returned.
 - a. The parts numbers and descriptions must match the current parts price list.
 - b. The list must be typed or computer generated.
 - c. The list must state the reason(s) for the return.
 - d. The list must reference the sales order(s) or invoice(s) under which the items were originally purchased.
 - e. The list must include the name and phone number of the person requesting the RMA.
3. A copy of the Return Material Authorization must accompany the return shipment.
4. Freight is at the sender's expense. All parts must be returned freight prepaid to Multiquip's designated receiving point.

5. Parts must be in new and resalable condition, in the original Multiquip package (if any), and with Multiquip part numbers clearly marked.
6. The following items are not returnable:
 - a. Obsolete parts. (If an item is in the price book and shows as being replaced by another item, it is obsolete.)
 - b. Any parts with a limited shelf life (such as gaskets, seals, "O" rings, and other rubber parts) that were purchased more than six months prior to the return date.
 - c. Any line item with an extended dealer net price of less than \$5.00.
 - d. Special order items.
 - e. Electrical components.
 - f. Paint, chemicals, and lubricants.
 - g. Decals and paper products.
 - h. Items purchased in kits.
7. The sender will be notified of any material received that is not acceptable.
8. Such material will be held for five working days from notification, pending instructions. If a reply is not received within five days, the material will be returned to the sender at his expense.
9. Credit on returned parts will be issued at dealer net price at time of the original purchase, less a 15% restocking charge.
10. In cases where an item is accepted, for which the original purchase document can not be determined, the price will be based on the list price that was effective twelve months prior to the RMA date.
11. Credit issued will be applied to future purchases only.

PRICING AND REBATES

Prices are subject to change without prior notice. Price changes are effective on a specific date and all orders received on or after that date will be billed at the revised price. Rebates for price declines and added charges for price increases will not be made for stock on hand at the time of any price change.

Multiquip reserves the right to quote and sell direct to Government agencies, and to Original Equipment Manufacturer accounts who use our products as integral parts of their own products.

SPECIAL EXPEDITING SERVICE

A \$35.00 surcharge will be added to the invoice for special handling including bus shipments, insured parcel post or in cases where Multiquip must personally deliver the parts to the carrier.

LIMITATIONS OF SELLER'S LIABILITY

Multiquip shall not be liable hereunder for damages in excess of the purchase price of the item with respect to which damages are claimed, and in no event shall Multiquip be liable for loss of profit or good will or for any other special, consequential or incidental damages.

LIMITATION OF WARRANTIES

No warranties, express or implied, are made in connection with the sale of parts or trade accessories nor as to any engine not manufactured by Multiquip. Such warranties made in connection with the sale of new, complete units are made exclusively by a statement of warranty packaged with such units, and Multiquip neither assumes nor authorizes any person to assume for it any other obligation or liability whatever in connection with the sale of its products. Apart from such written statement of warranty, there are no warranties, express, implied or statutory, which extend beyond the description of the products on the face hereof.

Effective: February 22, 2006

PARTS MANUAL

HERE'S HOW TO GET HELP

PLEASE HAVE THE MODEL AND SERIAL
NUMBER ON-HAND WHEN CALLING

UNITED STATES

Multiquip Corporate Office

18910 Wilmington Ave.
Carson, CA 90746
Contact: mq@multiquip.com

Tel. (800) 421-1244
Fax (310) 537-3927

Service Department

800-421-1244
310-537-3700

Fax: 310-537-4259

Technical Assistance

800-478-1244

Fax: 310-943-2238

MQ Parts Department

800-427-1244
310-537-3700

Fax: 800-672-7877
Fax: 310-637-3284

Warranty Department

800-421-1244
310-537-3700

Fax: 310-943-2249

CANADA

Multiquip

4110 Industriel Boul.
Laval, Quebec, Canada H7L 6V3
Contact: jmartin@multiquip.com

Tel: (450) 625-2244
Tel: (877) 963-4411
Fax: (450) 625-8664

UNITED KINGDOM

Multiquip (UK) Limited Head Office

Unit 2, Northpoint Industrial Estate,
Globe Lane,
Dukinfield, Cheshire SK16 4UJ
Contact: sales@multiquip.co.uk

Tel: 0161 339 2223
Fax: 0161 339 3226

© COPYRIGHT 2014, MULTIQUIP INC.

Multiquip Inc, the MQ logo are registered trademarks of Multiquip Inc. and may not be used, reproduced, or altered without written permission. All other trademarks are the property of their respective owners and used with permission.

This manual MUST accompany the equipment at all times. This manual is considered a permanent part of the equipment and should remain with the unit if resold.

The information and specifications included in this publication were in effect at the time of approval for printing. Illustrations, descriptions, references and technical data contained in this manual are for guidance only and may not be considered as binding. Multiquip Inc. reserves the right to discontinue or change specifications, design or the information published in this publication at any time without notice and without incurring any obligations.

Your Local Dealer is:



34776